

Synchronous Control of a Static AC Induction Motor Drive

ALLAN B. PLUNKETT, MEMBER, IEEE, JOHN D. D'ATRE, MEMBER, IEEE, AND THOMAS A. LIPO, SENIOR MEMBER, IEEE

Abstract—Conventional methods of controlling an induction motor utilize regulation of stator current and motor slip frequency in order to maintain system stability. This control strategy requires a shaft speed feedback and fast-response current regulation. An alternative method of controlling an induction motor is presented which achieves the necessary system stabilization by controlling only the motor frequency. The control inherently regulates the motor torque angle by properly adjusting the phase of the converter firing signals. By synchronizing the inverter firing pulses to the motor back electromotive force (EMF) possible adverse inverter operating modes are avoided. The concept of synchronous control eliminates the preprogrammed functional relations previously required and allows the control to adapt to any desired motor flux level. Any desired outer regulating loop can be incorporated to form a fast-response wide-range ac drive system.

INTRODUCTION

DURING recent years the development of static ac drives has opened up new fields of application for ac machines. These new applications have, in turn, necessitated the development of fast-response high-accuracy regulating systems. One regulating system which has prompted considerable attention is the current regulated induction motor drive. The basic configuration of such a drive is shown in Fig. 1. In this system ac or dc power is converted to variable amplitude dc power by means of a phase-controlled ac/dc rectifier or dc/dc chopper. The power is then converted to ac form by means of a dc/ac converter. A filter is inserted in the dc link so as to smooth the ripple currents inherent in rectifier or chopper operation. Alternatively, the ac to ac conversion could be accomplished in one step by use of a cycloconverter.

In order to realize practical operation of both motor and converter, stabilizing feedback must often be used to maintain normal motor flux and current levels [1]. Conventional control methods realize this stabilization by dynamic control of the motor current amplitude. Such strategy requires that the converter respond over the entire operating speed-torque range since system stability could be lost should the converter (rectifier, chopper, or cycloconverter) be phased fully on. The constraint severely limits the speed range over which such systems can be practically applied since operation in the "field weakening" or constant horsepower mode becomes difficult. In addition to current regulation, a function of current is used

Paper ID 77-6, approved by the Industrial Drives Committee of the IEEE Industry Applications Society for presentation at the 1977 Industry Applications Society Annual Meeting, Los Angeles, CA, October 2-4.

A. B. Plunkett and T. A. Lipo are with Corporate Research and Development, General Electric Company, Schenectady, NY 12301.

J. D. D'Atre is with the Electric Utility System Engineering Department, General Electric Company, Schenectady, NY 12301.

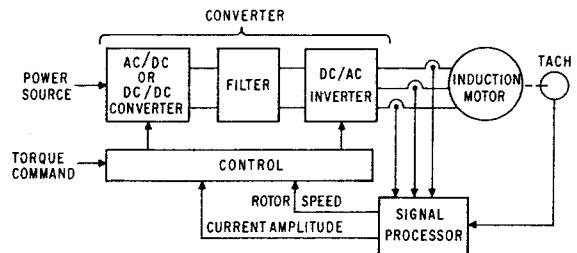

Fig. 1. Static ac drive with current and speed feedback.

to set the motor slip frequency which together with a motor speed feedback signal sets the inverter firing frequency [2], [3]. This functional relationship between link current and slip frequency is established to maintain, approximately, a constant flux in the motor as a function of load. The motor electrical slip frequency can also be calculated from terminal voltage and current [4]. However, accurate knowledge of motor parameters is required. Since motor parameters change with stator current, air gap flux, rotor frequency, and temperature, these regulation schemes are inherently difficult to operate over a wide range of speed and load. Stability can also be maintained by controlling power factor [5], but parameter changes again deteriorate performance.

In this paper an alternative method of control is presented. The scheme utilizes the inverter frequency as the necessary system stabilizing control, while the current amplitude merely adjusts the motor steady-state flux level. The stabilization is achieved by regulating the phase angle between motor current and motor flux. This approach causes the inverter firing pulses to synchronize to the motor counter electromotive force (CEMF) and is the dual of the voltage-fed induction motor wherein additional current is inherently provided to align the motor CEMF to the inverter [6].

The concept of synchronous control evolved from a desire to synchronize current flow in the inverter with respect to motor CEMF. It appears that an inverter with current regulation functions very much as a phase-controlled rectifier operating in the inverting mode. The firing angle of the inverter must be synchronized with respect to the motor voltage (or internal flux) in order to smoothly control power flow. Lack of synchronization results in an effect similar to the oscillation of a synchronous motor subjected to a sudden load change in which the rotor of the machine oscillates with respect to synchronous speed. Damping of rotor swings in a synchronous motor is obtained from short-circuited rotor windings which generate transient voltages, which in turn draw transient currents from the power supply to damp the oscillation. In the case of an induction motor supplied by a current

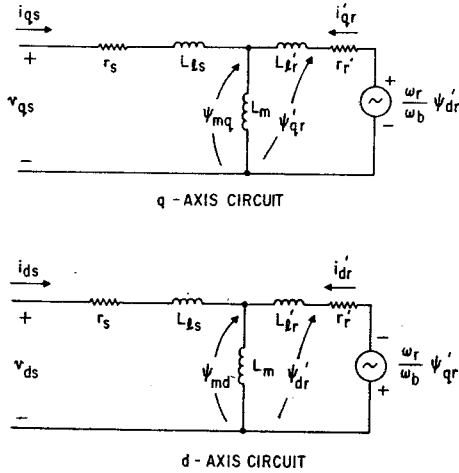

Fig. 2. Induction motor d - q equivalent circuit in stationary reference frame.

source, a similar oscillating effect exists. However, the required damping current does not inherently flow from the power supply. By synchronizing the converter to the motor CEMF such hunting-type instabilities can be eliminated.

In addition to stability problems caused by hunting, difficulties are also introduced by converter commutation. Commutation introduces a time delay between the firing of a converter thyristor and the instant of actual current transfer in the motor lines. Ripple currents introduce additional random delays in the commutation time. Unless properly treated, these delays can cause difficulties in inverter firing and in subsequent loss of control. The concept of synchronous control allows the effects of variable inverter commutation delay to be attenuated by the gain within the regulation loop. Synchronous control also offers the possibility of tachometerless operation. The expense and mechanical problems associated with a tachometer can be eliminated.

GENERAL CONCEPTS

The conventional d - q axes equivalent circuit of a squirrel-cage induction motor expressed in a reference frame fixed in the stator [7] is given in Fig. 2. The quantities shown are the standard motor equivalent circuit parameters defined in the usual manner. The variables ψ_{mq} , ψ_{md} , ψ_{qr}' , and ψ_{dr}' correspond to the q - and d -axis air gap and rotor flux linkages, respectively. These flux quantities carry units of voltage, are equal to the corresponding flux linkages λ times ω_b , the base angular frequency, and are defined by

$$\psi_{mq} = \omega_b L_m (i_{qs} + i_{qr}') \tag{1}$$

$$\psi_{md} = \omega_b L_m (i_{ds} + i_{dr}') \tag{2}$$

$$\psi_{qr}' = \omega_b [(L_m + L_{lr}') i_{qr}' + L_m i_{qs}] \tag{3}$$

$$\psi_{dr}' = \omega_b [(L_m + L_{lr}') i_{dr}' + L_m i_{ds}] \tag{4}$$

In general, the superscript "s" is usually affixed to the d - q variables to signify the stator reference frame, but the practice is omitted here for convenience. The quantities $(\omega_r/\omega_b)\psi_{qr}'$ and $(\omega_r/\omega_b)\psi_{dr}'$ can be considered as equivalent to the gener-

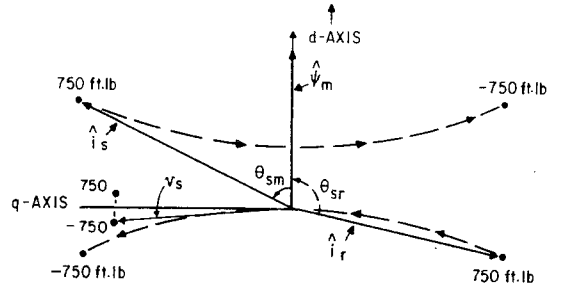

Fig. 3. Loci of voltage, current, and flux linkage vectors with load at rated frequency.

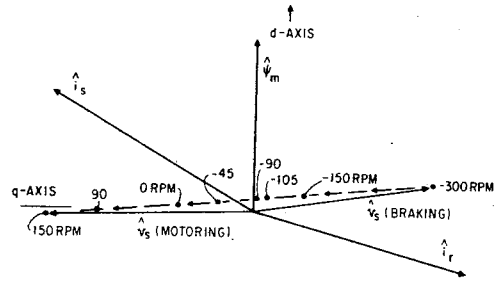

Fig. 4. Loci of voltage, current, and flux linkage vectors during speed reversal. Torque maintained constant.

ated CEMF of the motor and are cross-coupled between the d and q axes.

Figs. 3 and 4 are vector diagrams portraying the q - and d -axis quantities as two components of a vector in order to show the interrelations which exist between variables. In particular, Fig. 3 shows the change in angular position of the motor current vectors as a function of load at a rated speed using the air gap flux linkage vector as a reference. The parameters of an experimental system given in the Appendix were used, wherein 750 ft·lb corresponds approximately to the rated load. At no load, the flux and current vector are in phase and 90° out of phase with the terminal voltage vector. When the motor load increases rotor current must be developed, which in turn requires a counteracting component of stator current.

It can be observed that the stator voltage vector \hat{v}_s does not significantly change position with load, so that the frequency (or phase) of a voltage source need not vary with changes in load. The voltage source also offers an inherent stabilizing action by supplying damping current so that the motor is able to rapidly align to any new operating condition without assistance from the inverter. On the other hand, it can be noted that the stator current magnitude and angle change rapidly with load. The angular relation between current and motor flux now depends on the inverter firing and must be artificially provided by the control when a current source is employed. In addition, sufficient damping must be provided by the control for good transient behavior since the damping currents which normally flow are not inherently present.

A similar realignment effect occurs with voltage source inverters at low speeds, except it is now the terminal voltage vector that must be changed with respect to the flux vector. Fig. 4 shows a vector diagram illustrating a transition through zero speed while maintaining a torque constant. It should be noted that the current and flux linkage vectors remain rela-

tively fixed while the terminal voltage vector varies widely in angle and magnitude with speed. The firing pulses of a voltage inverter source must now be aligned at the correct phase with respect to the motor flux such that a change from braking to motoring can occur without a transient. An angle control is now required when operating from a voltage source. Note, however, that with a current source the corresponding flux-current vector alignment is achieved without difficulty.

CALCULATION OF THE TORQUE ANGLE

In general, the calculation of the torque angle necessitates sensing motor electrical variables since this quantity cannot be directly measured as with a synchronous machine. One alternative is to measure the motor line current and terminal voltage and back-calculate the flux angular position from the per phase induction motor equivalent circuit. Unfortunately, motor parameters vary from motor to motor with temperature and with load conditions, so that such compensation may become inaccurate, particularly at low speeds where resistance drop becomes the largest portion of motor voltage. A preferred method is to sense the air gap flux directly [8], [9]. Since the air gap flux is the result of both stator and rotor currents the actual rotor circuit operating conditions are sensed, and the inaccuracies involved in terminal measurements can be eliminated.

It can be shown that when stator current and air gap flux linkages are written as vectors having d and q components, then the electromagnetic torque can be expressed as

$$\hat{T}_e = \left(\frac{3}{2}\right) \left(\frac{P}{2}\right) \frac{1}{\omega_b} \hat{i}_s x \hat{\psi}_m \quad (5)$$

where P is the number of motor poles and "x" denotes the cross product between the current and flux linkage vectors. Equation (5) can be written alternatively as

$$T_e = \left(\frac{3}{2}\right) \left(\frac{P}{2}\right) \frac{1}{\omega_b} |\hat{i}_s| |\hat{\psi}_m| \sin \theta_{sm} \quad (6)$$

where θ_{sm} is the angle between \hat{i}_s and $\hat{\psi}_m$. Thus the torque angle can be computed from the equation

$$\sin \theta_{sm} = \frac{4\omega_b T_e}{3P |\hat{i}_s| |\hat{\psi}_m|} \quad (7)$$

In general, (7) is the most straightforward means for computing the torque angle. However, other forms for the torque equation exist which yield other possible flux-current relationships. It can be shown that (8)–(10) are alternative expressions for an instantaneous electromagnetic torque [10]:

$$\hat{T}_e = \left(\frac{3}{2}\right) \left(\frac{P}{2}\right) \frac{1}{\omega_b} \hat{\psi}_m x \hat{i}_r \quad (8)$$

$$\hat{T}_e = \left(\frac{3}{2}\right) \left(\frac{P}{2}\right) \frac{1}{\omega_b} \hat{\psi}_s x \hat{i}_r \quad (9)$$

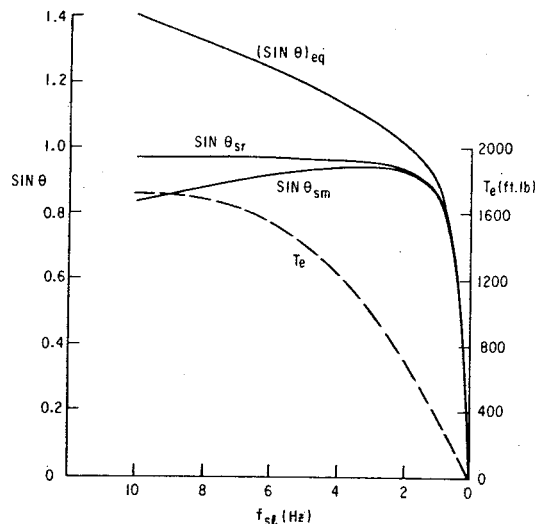

Fig. 5. Torque and torque angle as function of slip.

$$\hat{T}_e = \left(\frac{3}{2}\right) \left(\frac{P}{2}\right) \frac{1}{\omega_b} \hat{i}_s x \hat{\psi}_r \quad (10)$$

where $\hat{\psi}_s$ denotes the total stator flux linkage vector and \hat{i}_r is the rotor current vector. Unfortunately the rotor current cannot be monitored directly, so that (8) and (9) are difficult to implement. However, from (1)–(4) the rotor and air gap flux linkages can be written as

$$\hat{\psi}_r = x_{lr}' \hat{i}_r + \hat{\psi}_m \quad (11)$$

$$\hat{\psi}_m = x_m (\hat{i}_s + \hat{i}_r) \quad (12)$$

where $x_{lr}' = \omega_b L_{lr}'$ and $x_m = \omega_b L_m$. Upon algebraically eliminating \hat{i}_r , (11) can be written as

$$\hat{\psi}_r = \frac{x_r'}{x_m} \hat{\psi}_m - x_{lr}' \hat{i}_s \quad (13)$$

where $x_r' = x_{lr}' + x_m$. Hence the rotor flux linkage vector can be mechanized from the air gap flux linkages and stator current. The angle θ_{sr} between \hat{i}_s and $\hat{\psi}_r$ corresponding to (10) can also be viewed as a torque angle. The angle θ_{sr} is defined by

$$\sin \theta_{sr} = \frac{4\omega_b T_e}{3P |\hat{i}_s| |\hat{\psi}_r|} \quad (14)$$

and $\hat{\psi}_r$ is derived from (13).

The quantities $\sin \theta_{sm}$ and $\sin \theta_{sr}$ are plotted as functions of slip frequency in Fig. 5. Again the system parameters given in the Appendix were used. It can be noted that the quantity $\sin \theta_{sm}$ is a double-valued function of torque when the slip frequency increases from zero to breakdown. Since the angle control is located within a torque regulation loop, difficulties can be anticipated by this double-valued behavior. It can be noted that the angle between stator current and rotor flux is not double-valued but reaches a maximum of 90° when the slip frequency approaches breakdown. However, the angle

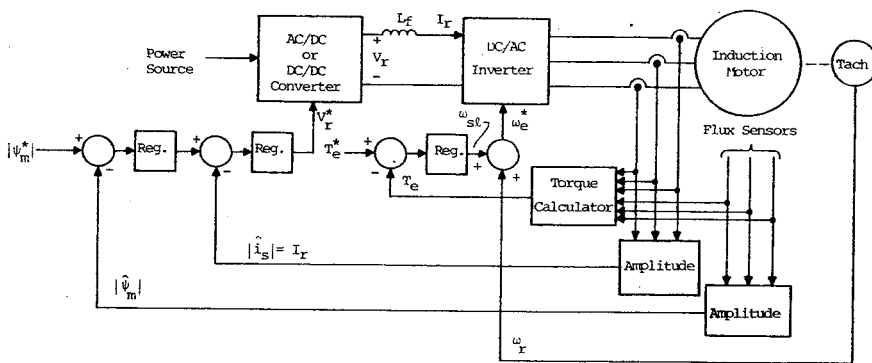

Fig. 6. Control scheme employing flux amplitude and torque regulation.

change is very small at high slips, indicating the low gain and consequent poor regulation.

One practical modification of this angle measurement technique is to basically provide a corrective signal to ensure that a monotonic relationship is maintained between torque and angle. Although (13) is a vector relationship it is interesting to consider the approximate relationship

$$|\hat{\psi}_r| \cong \frac{x_r'}{x_m} |\hat{\psi}_m| - x_{lr}' |\hat{i}_s| \quad (15)$$

Equation (14) becomes

$$(\sin \theta)_{equiv} = \frac{4\omega_b T_e}{3P \left[\frac{x_r'}{x_m} |\hat{\psi}_m| - x_{lr}' |\hat{i}_s| \right] |\hat{i}_s|} \quad (16)$$

The equivalent angle quantity $(\sin \theta)_{equiv}$ is also plotted in Fig. 5. Note that this modified variable takes on values greater than unity and thus does not strictly correspond to an actual angle. Nonetheless, the quantity increases monotonically over the entire operating region and thereby suggests a feasible variable for regulation.

TRANSIENT BEHAVIOR OF SYNCHRONOUS CONTROL

Although it has been demonstrated that a modified value of the torque angle has desirable steady-state properties, a detailed dynamic analysis is required in order to verify that the proposed angle regulation scheme is feasible. One analysis technique which has proven ideally suited to this task is the computation of the relevant induction motor transfer functions [11]. As part of this technique the *d-q* equations which express dynamic behavior of the inverter-motor system are defined, linearized for small changes about an operating point, and recast in state-variable form [3]. The relevant transfer function input is defined and the output is identified in terms of the state variables. The equations are then transformed to phase-variable canonical form wherein the desired transfer function can be obtained by inspection. Having obtained the desired transfer function, any of the usual control design techniques can be employed such as the Bode plot, the root-locus plot, the Nichols chart, etc.

It has already been mentioned that when the dc voltage source is active, the required system stabilization can be

achieved by utilizing the dc link. One desirable control scheme which has been reported previously [9] is shown in Fig. 6. With this method the air gap flux magnitude and air gap torque are sensed. The dc voltage source is used to regulate the amplitude of the air gap flux and an inner current loop is provided to eliminate the time constant associated with the dc link inductor. In addition, slip frequency is adjusted to regulate the torque to the desired level.

In Fig. 7 the flux loop has been disabled and the dc link current loop has been closed through a simple gain G_i . That is,

$$V_r = G_i(I_r^* - I_r) \quad (17)$$

where the asterisk denotes the commanded value of the link current which is assumed constant. Fig. 7 shows the migration of the poles and zeros of the frequency loop transfer function between slip angular frequency and air gap torque $(\Delta T_e / \Delta \omega_{sl})$ as the gain G_i is increased in the dc link current regulator. The operating point considered is at rated frequency, rated terminal V/Hz, and a load of 750 ft·lb. The system parameters in the Appendix were again used. Note that although the system poles are in the right half-plane for zero gain, the poles move into the left half-plane with only a modest amount of feedback gain when the current regulator is in operation. Control of slip frequency is not required for stabilization. In Fig. 7 the effects of rotor speed changes have been neglected. Although rotor speed changes slightly modify the results of Fig. 7, the inertia will be assumed infinitely large throughout this study.

In Fig. 8 the behavior of the same transfer function is investigated. However, this time the current regulator is out of service, indicating that the dc voltage source is fixed. This condition corresponds to operation at high speeds in which the ac/dc rectifier or dc/dc chopper is phased full-on (fully conducting). Fig. 8 shows the location of the poles and zeros of $\Delta T_e / \Delta \omega_{sl}$ for a range of load points. Note that the system becomes unstable for loads above about 150 ft·lb. Moreover, the complex conjugate poles in the right half-plane are accompanied by a pair of zeros indicating that overall stability is not possible regardless of the feedback compensator used between the output ΔT_e and input $\Delta \omega_{sl}$. This behavior clearly points to the need for an improved control scheme during high-speed operation.

In Fig. 9 the sine of the angle between stator current and air gap flux linkage, $\sin \theta_{sm}$, has been implemented by means

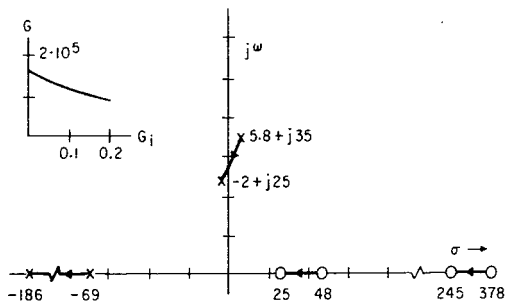

Fig. 7. Poles (x), zeros (o), and gain (G) of transfer function $\Delta T_e/\Delta\omega_{sl}$ for increasing link current regulator gain G_i . Initial point $G_i = 0$, final point $G_i = 0.2$. Operating condition 50 Hz, 210 V, 750 ft·lb.

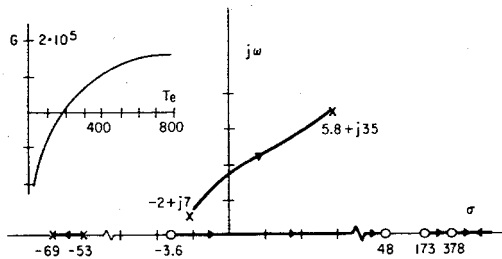

Fig. 8. Poles (x), zeros (o), and gain (G) of transfer function $\Delta T_e/\Delta\omega_{sl}$ with constant dc link voltage. Effect of increasing load torque with rated terminal voltage and frequency. Initial point $T_e = 25$, final point $T_e = 750$ ft·lb.

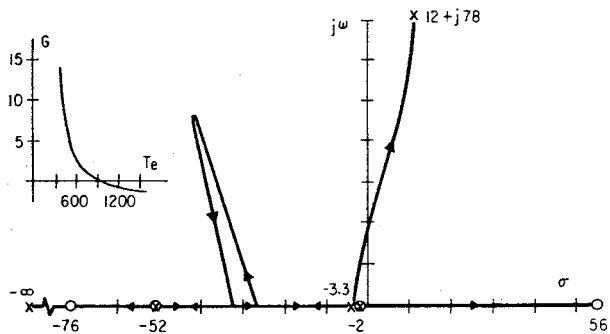

Fig. 9. Poles (x), zeros (o), and gain (G) of transfer function $\Delta \sin \theta_{sm}/\Delta\omega_{sl}$ with constant dc link voltage. Effect of increasing load torque with rated terminal voltage and frequency. Initial point $T_e = 0$ (no-load), final point $T_e = 1675$ ft·lb (breakdown).

of (7). The poles and zeros of $\Delta(\sin \theta_{sm})/\Delta\omega_{sl}$ are plotted over the same range of operating conditions as in Fig. 8. Since the transfer function pole locations are independent of input and output, the poles again enter the right half-plane at 150 ft·lb as load is increased. In this case the zeros originate at -2 and -52 at no load. The zeros move together, break off the real axis, and then return at a load of 500 ft·lb. Up to this point the zeros migrate only in the left half-plane indicating that stabilization remains feasible. However, as load continues to increase, one of the zeros moves to the right and finally enters the right half-plane beyond 1000 ft·lb. The point at which this zero changes sign corresponds to the inflection point of the plot of $\sin \theta_{sm}$ versus f_{sl} in Fig. 5. In general, one of the right half-plane poles will be attracted to this zero as feedback gain is increased so that stabilizing feedback compensation appears impractical if not impossible.

Fig. 10 shows the pole-zero locations when the quantity $\sin \theta_{sr}$ is measured rather than $\sin \theta_{sm}$. It can be noted that

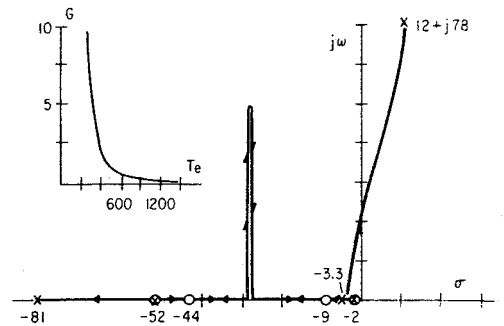

Fig. 10. Poles (x), zeros (o), and dc gain (G) of transfer function $\Delta \sin \theta_{sr}/\Delta\omega_{sl}$ with constant dc link voltage. Effect of increasing load torque with rated terminal voltage and frequency. Initial point $T_e = 0$, final point $T_e = 1675$ ft·lb.

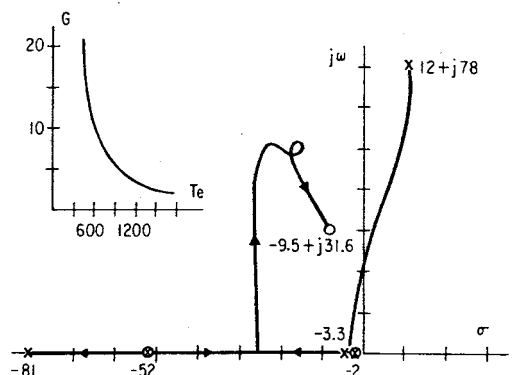

Fig. 11. Poles (x), zeros (o), and dc gain (G) of transfer function $\Delta \sin \theta_{equiv}/\Delta\omega_{sl}$ with constant dc link voltage. Effect of increasing load torque with rated terminal voltage and frequency. Initial point $T_e = 0$, final point $T_e = 1675$ ft·lb.

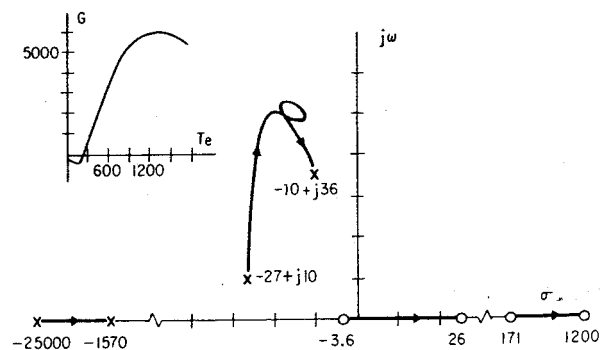

Fig. 12. Poles (x), zeros (o), and dc gain (G) of transfer function $\Delta T_e/\Delta(\sin \theta)^*$. Angle loop closed through gain $G = 10$. Initial point $T_e = 25$, final point $T_e = 1675$ ft·lb.

the zeros are better behaved and never enter the right half-plane. However, the system gain changes dramatically with load. Although it is possible to compensate with a feedback gain which increases inversely with load, such a technique is difficult to mechanize because practical considerations such as noise and sampling effects begin to affect performance.

In Fig. 11 the modified angle derived from (15) and (16) is considered as the feedback variable. Again, operation at 50 Hz is assumed. As noted previously, the open loop system poles are in the right half-plane for heavy loads. However, the system zeros remain in the left half-plane over the full range of operating conditions. Loop closure is now practical and system stability can be maintained for motoring loads. Fig. 12 indi-

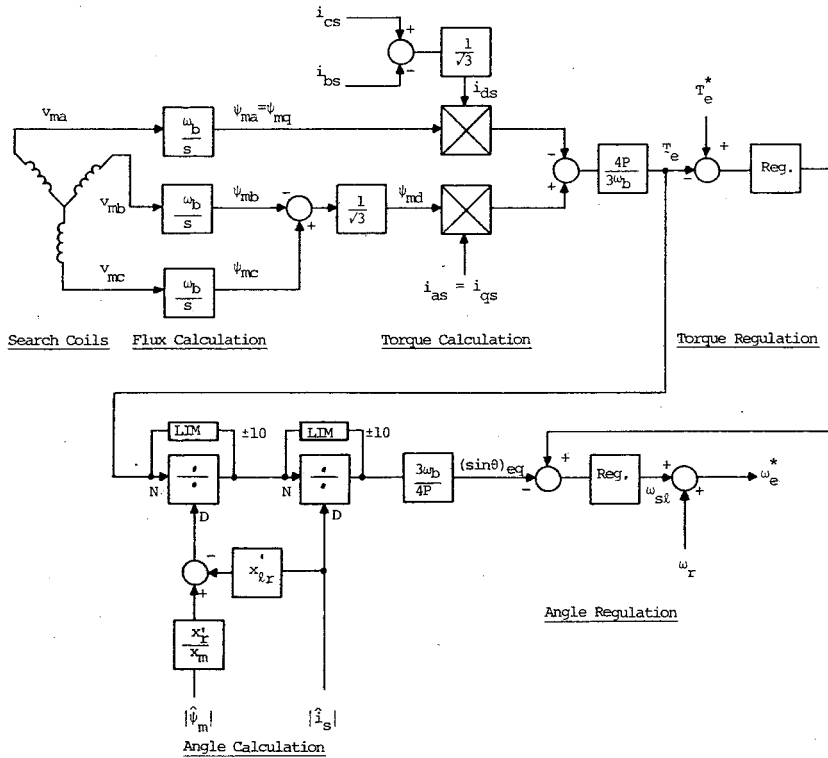

Fig. 13. Torque regulation scheme employing angle regulation.

icates the resulting pole-zero locations when the transfer function $\Delta(\sin \theta)_{equiv} / \Delta \omega_{sl}$ has been closed through a feedback gain $G_\theta = 10$. The poles and zeros in the subsequent outer loop $\Delta T_e / \Delta(\sin \theta)^*$ are shown. It is evident that system stability has been provided by the inner feedback loop, and closure of the torque regulating loop can now proceed without difficulty. Although rated line frequency has been assumed throughout this discussion, it can be shown that the system poles and zeros are not materially affected by operating frequency [3] so that these conclusions are valid over a wide speed range.

EXPERIMENTAL RESULTS

Fig. 13 depicts the overall method of torque angle calculation and regulation which has been successfully implemented. This scheme consists of calculating electromagnetic torque which is then normalized by magnitude of current and magnitude of flux linkage. The intermediate signals of torque, flux magnitude, and current magnitude are already required for use in other control loops which set the desired operating points for the motor [9] so that additional sensors are not required. In order to obtain a meaningful angle signal at start-up or under abnormal operating conditions, the values of $|\hat{i}_s|$ and $|\hat{\psi}_m|$ are fed to two dividers which have a minimum value set by a nonlinear limiter so that division by zero is avoided.

An alternative approach to the angle calculation which is somewhat restrictive in that saturation is not properly taken into account is shown in Fig. 14. In this case the flux and current signals are amplified, limited, and then connected to multipliers. The result is an angle signal which is not dependent on the magnitude of flux and current but only on their relative phase. For small amplitudes of current or flux, the calculation will properly yield a zero output. Division is not re-

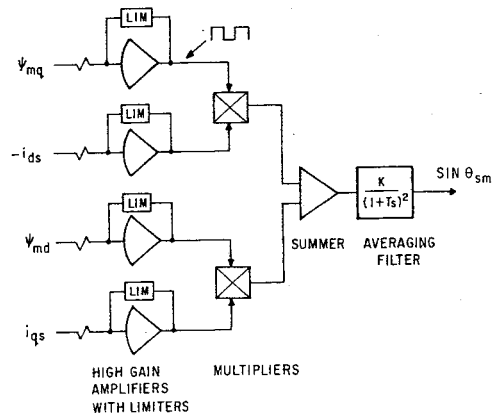

Fig. 14. Alternate angle computation.

quired. This method should lend itself well to digital implementation, although near zero speed continuous information will not be available from the digital phase detection circuit.

The control system which has been described has been thoroughly instrumented and tested. Fig. 15 shows a representative system transient response for a step change in a commanded angle while operating in the motoring mode. The system parameters are again those summarized in the Appendix except that $L_f = 1.0$ mH. The dc source consists of a conventional six-pulse rectifier bridge supplied by fixed ac voltages. The chart traces display current magnitude, torque, $(\sin \theta)_{equiv}$, and motor slip frequency. It can be noted that the angle follows the command very quickly (rise time $\cong 0.04$ s), but it takes about 0.1 s for the torque and current to respond. The slow drift in torque (about 1.0 s time constant) is due to the change in the speed of the dc load motor as the torque level changes. The lower frequency ripple in the current is due to the beat between motor frequency and the rectifier

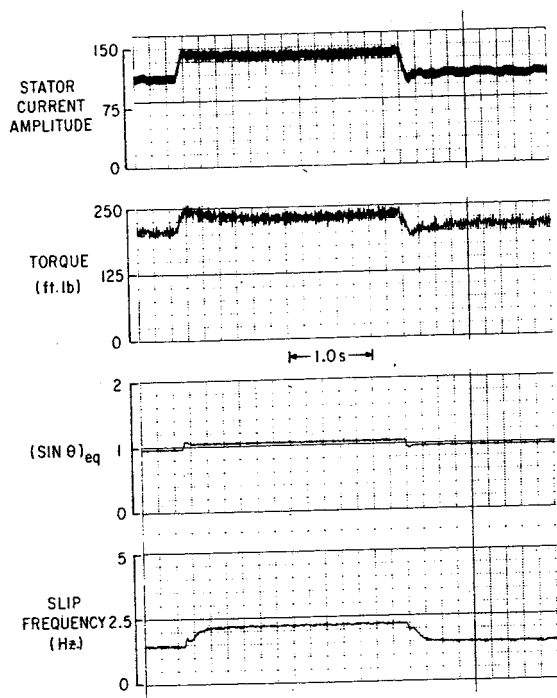

Fig. 15. Performance of prototype system for step changes in angle command with fixed dc source voltage.

ac source frequency. The high-frequency ripple is due to the pulsations in link current caused by inverter commutation. These results clearly show that accurate fast torque control can be achieved with synchronous control. Moreover, operation without current loop stabilization is entirely feasible.

CONCLUSION

The regulation of the angle between motor flux and current offers several direct benefits when an induction motor is supplied from a static converter. Most important, the necessary stabilizing force is exerted by inverter frequency alone, thus easing the requirements on the converter supply. Overall system stability and transient response have been shown to be enhanced by synchronous control. Moreover, the synchronization of inverter firing pulses to motor flux eliminates possible abnormal inverter commutation conditions. Problems involved with motor speed reversal with either current or voltage inverters is greatly reduced due to the vector alignment capability of the control. If necessary, mechanical sensing of shaft speed can be eliminated by controlling the torque angle since the system is self-synchronous. The basic control scheme should also be beneficial to synchronous motor drives since the control scheme which has been described does not require rotor position sensing nor armature reaction compensation.

APPENDIX

Motor Rating

Rated Voltage	210 V rms 1-n.
Rated Frequency	50 Hz.
Breakdown Torque	1675 ft·lb.
Poles	4.

Motor Parameters at 50 Hz

$$\begin{aligned} r_s &= 0.0172 \Omega. \\ x_{ls} &= 0.0706 \Omega. \\ r_r' &= 0.0310 \Omega. \\ x_{lr}' &= 0.0903 \Omega. \\ x_m &= 2.8413 \Omega. \end{aligned}$$

DC Link Parameters

$$\begin{aligned} L_f &= 1.824 \text{ mH.} \\ r_f &= 0.055 \Omega. \end{aligned}$$

REFERENCES

- [1] T. A. Lipo and E. P. Cornell, "State variable steady-state analysis of a controlled current induction motor drive," *IEEE Trans. Ind. Appl.*, vol. IA-11, pp. 704-712, Nov./Dec. 1975.
- [2] R. B. Maag, "Characteristics and application of current source/slip regulated ac induction motor drives," in *IEEE/IAS Annu. Meeting Conf. Rec.*, pp. 411-417, Oct. 18-21, 1971.
- [3] T. A. Lipo and E. P. Cornell, "Modeling and design of controlled current induction motor drive systems," in *IEEE/IAS Annu. Meeting Conf. Rec.*, pp. 612-620, Sept. 28-Oct. 2, 1975.
- [4] A. Abbondanti and M. B. J. Brennen, "Control of induction motor drives by synthesis of a slip signal," *IEEE/IAS Annu. Meeting Conf. Rec.*, pp. 845-850, Oct. 7-10, 1974.
- [5] G. R. Slemon, J. B. Forsythe, and S. B. Dewan, "Controlled power angle synchronous motor inverter drive system," *IEEE Trans. Ind. Appl.*, vol. IA-8, pp. 679-683, Nov./Dec. 1973.
- [6] N. Remesh and S. D. T. Robertson, "Induction machine instability predictions—Based on equivalent circuits," *IEEE Trans. Power App. Syst.*, vol. PAS-92, pp. 801-807, Mar./Apr. 1973.
- [7] P. C. Krause and C. H. Thomas, "Simulation of symmetrical induction machinery," *IEEE Trans. Power App. Syst.*, vol. PAS-84, pp. 1038-1053, Nov. 1965.
- [8] F. Blaschke, "The method of field orientation for the control of induction machines," *Siemens Forsch. u. Entwickl.*, pp. 184-193, Jan. 1972, (in German).
- [9] A. B. Plunkett, "Direct flux and torque regulation in a PWM inverter-induction motor drive," in *IEEE/IAS Annu. Meeting Conf. Rec.*, pp. 591-597, Sept. 28-Oct. 2, 1975.
- [10] K. P. Kovacs and I. Racz, *Transient Behavior of AC Machines* Budapest: Hungarian Academy of Science, 1959, (in German).
- [11] T. A. Lipo and A. B. Plunkett, "A novel approach to induction motor transfer functions," *IEEE Trans. Power App. Syst.*, vol. PAS-93, pp. 1410-1418, Sept./Oct. 1974.

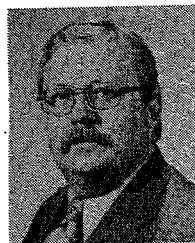

Allan B. Plunkett (S'66-M'70) received the B.S. degree in electrical engineering from Texas Western College, El Paso, TX, in 1965, and the M.S. and Ph.D. degrees from the University of Texas, Austin, in 1967 and 1970, respectively.

He has been with General Electric since 1970, primarily with the Transportation Division where he has developed the power converter and control for an ac induction motor powered transit car. Also, he has been engaged in electric locomotive power factor improvement, a study on regenerating transit car braking energy, and induction motor-current inverter drive development. Since joining Corporate Research and Development, General Electric Co., Schenectady, NY, in 1976, he has worked on a study for a flywheel powered bus, a hybrid computer simulation of the control strategy for a synchronous motor-load commutated inverter drive, and digital computer transfer function analysis for an induction motor-current inverter drive. His special field of interest is the application of semiconductor power converters applied to motor drives. He is currently working on the control of induction motors using a current inverter and a synchronous motor drive using a load commutated inverter.

Dr. Plunkett has authored a number of technical papers on motor

drive control using static power converters. He has 16 patent applications filed with 12 patents granted. He is a member of the AAAS and Sigma Xi.



John D. D'Atre (S'67-M'68) was born in Fitchburg, MA, on April 26, 1946. He received the B.S.E.E. degree from the New Jersey Institute of Technology, Newark, in 1968, and the M.E.E. degree in engineering from Rensselaer Polytechnic Institute, Troy, NY, when he completed the General Electric Advanced Course in Engineering in 1971.

He has been with the General Electric Company since 1968 and has worked in the area of ac motor control and microprocessor imple-

mentations for various components of the company. Since 1977 he has been an analytical engineer within the Electric Utility Systems Engineering Department, General Electric Company, Schenectady, NY.

Mr. D'Atre is a member of Tau Beta Pi and Eta Kappa Nu, and he holds ten U.S. patents.

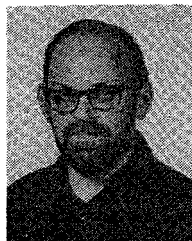

Thomas A. Lipo (M'64-SM'71) was born in Milwaukee, WI, on February 1, 1938. He received the B.E.E. degree with honors and the M.S.E.E. degree from Marquette University, Milwaukee, WI, in 1962 and 1964, respectively, and the Ph.D. degree in electrical engineering from the University of Wisconsin, Madison, in 1968.

From 1959 to 1964 he completed both the Cooperative Training Course and the Graduate Training Course at the Allis-Chalmers Manufacturing Company, Milwaukee, WI. During 1968-1969 he was an S.R.C. Postdoctoral Fellow at the University of Manchester Institute of Science and Technology, Manchester, England. Since 1969 he has been an Electrical Engineer in the Electronic Power Conditioning and Control Laboratory, Research and Development Center, General Electric Company, Schenectady, NY. During the academic year 1973-1974, he was a visiting Associate Professor at Purdue University, West Lafayette, IN. At General Electric he has been engaged in the development of static converter systems for a variety of applications including linear motors, static exciters, ball mills, turbine-generator rotor balancing, pumped-hydro and traction drives for rail, off- and on-highway vehicles.