

Wisconsin Electric Machines and Power Electronics Consortium

RESEARCH REPORT
89-21

USING INDUCTION MOTOR STATOR WINDINGS
TO EXTRACT SPEED INFORMATION

Donald S. Zinger
University of Akron
Akron, Ohio 44325

Thomas A. Lipo and Donald W. Novotny
University of Wisconsin-Madison
1415 Johnson Drive
Madison, WI 53706-1691

WEMPEC

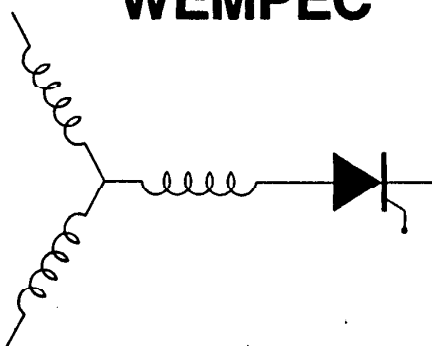

Department of Electrical and Computer Engineering
1415 Johnson Drive
Madison, Wisconsin 53706
June 1989

USING INDUCTION MOTOR STATOR
WINDINGS TO EXTRACT SPEED
INFORMATION

DONALD S. ZINGER
University of Akron
Akron, OH 44325

THOMAS A. LIPO DONALD W. NOVOTNY
University of Wisconsin
1415 Johnson Dr.
Madison, WI. 53706

ABSTRACT

Speed information is available from the moving flux wave in the air gap of an induction motor. The information takes the form of ripples in the flux caused by the motion of rotor bars through the flux wave. This information is accessed by using voltages available from taps taken off the stator windings. It is then isolated using a switched capacitor filter and captured using a frequency slaved loop. A speed regulator based on a field oriented control is then constructed using this speed information.

INTRODUCTION

The induction motor is a rugged device that can be used in extremely harsh environments. For use in many applications where speed control is desired it is often necessary to include additional devices for speed measurements. These devices are typically more fragile than the induction motor to which they are mounted, reducing the reliability of the overall system. It is therefore desirable to design a speed control without the use of such speed measuring devices.

One method of operation that does not require any speed sensors is to run the induction motor open loop with a variable frequency drive. This method uses the frequency of the drive to adjust the speed of the motor. Without any feedback, however, speed droop will occur due to slip under loaded conditions. Compensation for this droop can be made by using the dc link current to approximate the torque. Using this approximation, compensation for the slip can be made by adjusting the frequency appropriately. This method works well for many applications but is only an approximate method that depends on motor parameters. In some implementations the slip frequency can be directly calculated [1]. This, however, is highly dependant on the motor parameters and gives results suitable in only a few applications.

Slip information is, however, available from voltages that can be measured. These voltages are the direct result of disturbances caused by rotor slots moving through the air gap flux wave. Previous attempts to utilize this slot frequency have met with some success [2,3]. These systems were, however, complex and difficult to implement.

A new simpler approach has been developed to use these slot harmonics in a speed control. This method utilizes voltages generated in the separate coils of the stator windings [4]. A typical placement of such taps on the windings of a single phase is shown in Fig. 1. These voltages are measured by

placing intermediate taps on some of the stator coils. By properly summing these voltages information can be obtained for use in flux control as well as slot ripples for speed control [5]. Switched capacitor filters [6] are then used to isolate the desired slot harmonic and a frequency slave loop [7] is employed to generate a signal related to rotor speed.

FLUX RIPPLE

Ideally the windings and flux are sinusoidally distributed in an induction motor. Real windings are, however, distributed in discrete slots around the air gap and therefore differ somewhat from an ideal sinusoidal distribution. These nonsinusoidal distributions together with changes in permeance caused by the slots create harmonic distortions in the air gap flux.

For this application variations in the flux due to slots on the rotor are of particular importance. The placement of rotor bars at discrete intervals along the rotor create distortions in the flux wave that vary with the motion of the rotor through the flux. The resulting flux harmonics produce time variations in the induced voltages. Since these harmonics are directly related to rotor speed, they can be used as a means of measuring the speed of the rotor. The voltages induced in a coil of wire caused by a fundamental flux wave with these harmonics is represented by

$$\begin{aligned}
 v(\theta, \omega t) = & B_0 k_{B1} \omega \sin(\omega t - \theta) \\
 & + \frac{1}{2} B_0 k_n k_{B-1} (\omega_1) \sin[\omega_1 t - (N_r + 1) \theta] \\
 & + \frac{1}{2} B_0 k_n k_{B-} (\omega_2) \sin[\omega_2 t - (N_r - 1) \theta]
 \end{aligned}
 \tag{1}$$

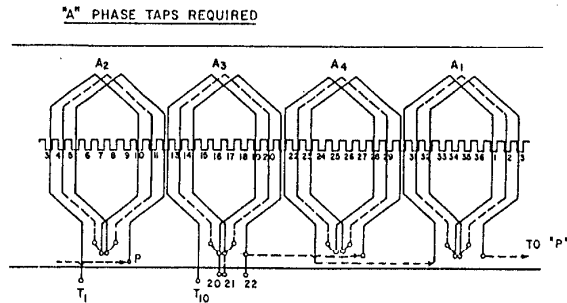

Fig. 1. Coil placement and taps one phase of a double layer lap winding having 7/9 slot pitch.

where

- θ - electrical position with respect to the stator'
- $\omega_1 = N_r \omega_r + 1$
- $\omega_2 = N_r \omega_r - 1$
- ω_r - mechanical speed in electrical rad/sec
- ω - supply frequency in electrical rad/sec
- N_r - number of rotor slots per pole pair
- B_0 - modulus of fundamental component of flux density
- k_n - amplitude ratio (dependant on rotor current)
- k_{Bx} = coil configuration constant for x harmonic

This equation shows the output voltage has components that are dependent on the rotor speed in both magnitude and frequency. Speed information is difficult to extract from the flux voltage magnitude because this magnitude depends not only on rotor speed but also on flux level settings and loading conditions. In particular the amplitude ratio (k_n) is a function of rotor current, increasing as the rotor current increases and making the induced voltage magnitude dependant on the load conditions of the motor. Because the magnitude is dependent on these other parameters, speed information can be more easily extracted from the frequency of these harmonics.

In order to extract the flux harmonic it is desirable to have a strong flux ripple component to start with. Although the rotor ripple component in most motors can be used to find the ripple frequency, motors are generally designed to reduce these harmonics. For example rotor slots are typically skewed to reduce audible noise and eliminate asynchronous crawling during line starts caused by these harmonics. A machine with unskewed rotor slots would produce stronger slot harmonics and therefore would be more desirable for extracting frequency information. Although this may cause some problem with noise, line starts would not be required for the motor eliminating the problem of asynchronous crawling.

ISOLATION OF SLOT HARMONIC

In a real situation the slot harmonics are smaller than many other harmonics available from a stator coil. An example of a spectrum of the voltage from a stator coil is shown in Fig. 2. It is seen that under no load the larger of the two slot harmonics is smaller than the third, fifth and seventh harmonics and comparable to the other harmonics. These undesired harmonics have to be reduced before the slot harmonic can be used in speed control.

One technique that can be employed to reduce many of these harmonics is to sum voltages from three coils separated by 120 electrical degrees [2]. For a given harmonic, h , the voltage resulting from such a harmonic would have the general form of

$$v_h = k \left[\sin(A) + \sin\left(A - \frac{2\pi h}{3}\right) + \sin\left(A + \frac{2\pi h}{3}\right) \right] \quad (2)$$

This equation has a zero value for all values of h except integer multiples of 3. Since h corresponds to $N_r + 1$ for the upper side band and $N_r - 1$ for the lower sideband, if the number of rotor slots is not a multiple of three then one and only one of the rotor slot harmonics will remain. Generally because of noise and vibration problems, the number of rotor slots is a non multiple of three [2,8]. By summing the three coil voltages all harmonics, except the desired slot harmonic and other harmonics that are multiples of three, can be eliminated.

Figure 3 shows a spectrum of the waveform obtained when summing the voltages of a proper set of three of the flux sensing coils. By comparing this graph to Fig. 2 a large decrease in all harmonics not a multiple of 3 is easily discernible. The frequency of concern ($N \omega_r + \omega$) stands out clearly from the rest of the harmonics, larger than all of them except the third.

Since summing of three coils reduced many harmonics, consideration was given to using all six coils in the flux sensing system to further reduce undesired harmonics including the third. By multiplying each coil by a gain the total voltage for a given harmonic can be represented by

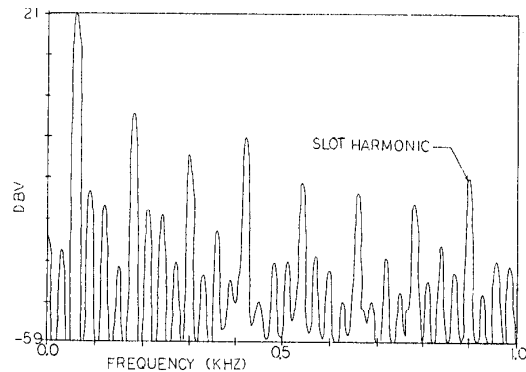

Fig. 2. Spectrum of voltage from a single tapped stator winding. No load operation with 60 Hz. sine wave excitation.

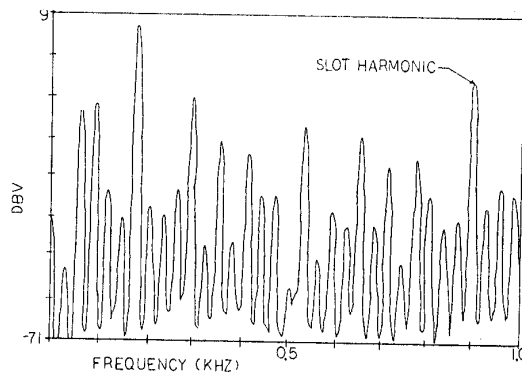

Fig. 3. Spectrum of voltage from sum of 3 coils under no load with 60 Hz sine wave excitation.

$$v_h = G_1 \sin[h(\omega t + \theta_1)] + G_2 \sin[h(\omega t + \theta_2)] + \dots + G_6 \sin[h(\omega t + \theta_6)] \quad (3)$$

Programs were developed to find optimum gain settings for reduction of different harmonics. The gains that were found, however, generally reduced the desired harmonic as well as the undesired harmonics. The net result showed little advantage over the use of a single coil. The best isolation of the desired harmonic was therefore found by simply summing voltages from coils in each phase.

Switched Capacitor Filters

After summing the voltages of tapped winding flux sensors from each of the three phases, the third harmonic is the only major component other than the desired slot harmonic. Since the slot harmonic frequency is typically on the order of five times that of the third harmonic, it should be possible to use a sharp filter to isolate the slot harmonic. In variable speed applications, however, the frequency could vary over a range of fifty to one. Thus one filter with a constant cutoff frequency could not be used in a typical variable speed application.

One economical method of obtaining an adjustable cutoff frequency is to use switched capacitor filters. These allow for simple adjustment of the cutoff frequency by regulating the switching frequency of the switched capacitor integrators, the basic element in a switched capacitor filter.

A schematic of a switched capacitor integrator is shown in Fig. 4. The operation of such an integrator is described in [6]. Essentially when switch ϕ is closed and $\bar{\phi}$ is open a charge ($Q = V_1 C_1$) is accumulated on capacitor C_1 . When ϕ opens and $\bar{\phi}$ closes the charge is transferred to capacitor C_f . For a switching period T the average current transferred to this capacitor is

$$I = \frac{Q}{T} = \frac{V_1 C_1}{T} \quad (4)$$

The average output voltage would be the integral of this current or

$$V_{OUT} = \int \frac{I}{C_f} dt = \frac{C_1}{C_f T} \int V_{IN} dt \quad (5)$$

Thus by changing the period of switching, the integrator gain ($C_1/C_f T$) can be changed. Using such integrators as energy storage devices in filters will allow for easy adjustment of cutoff frequencies. These types of filters are available commercially for many different configurations. The filter used for this study is a 6 pole Chebyshev band-pass filter.

Figure 5 shows the spectrum resulting from the application of a switched capacitor filter to the sum of the tapped stator windings from the three phases. From this figure it is seen that the desired slot harmonic is well isolated from all the other harmonics.

Of the methods considered, using the switched capacitor filter with the sum of voltages from a flux coil in each of the three phases gives the

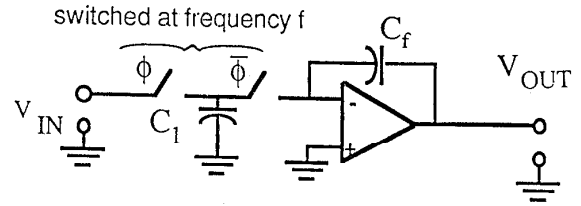

Fig. 4. Simplified schematic of switched capacitor integrator.

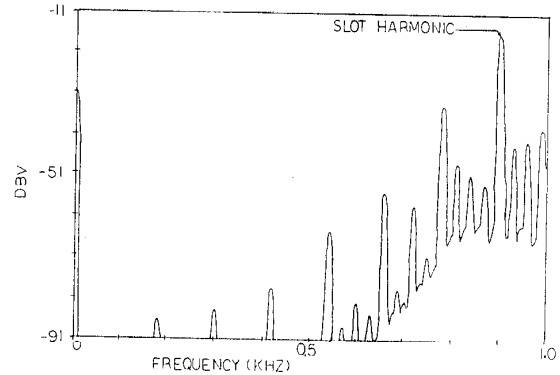

Fig. 5. Spectrum of voltage from sum of tapped windings with a switched capacitor filter. No load operation with 60 Hz. sine wave excitation.

best isolation of the desired slot harmonic. This is the method used in the final implementation.

RETRIEVING FREQUENCY INFORMATION

Once the desired slot harmonic is sufficiently isolated, the frequency information must be extracted from this signal. Methods have been developed that use zero crossing techniques to determine the frequency of the slot harmonic [2,3]. These methods work well at frequencies above 10 Hz but are complex to implement. A simpler method of generating an output voltage proportional to the rotor slot frequency can be implemented using a frequency slaved loop (FSL).

Circuits similar to FSLs have been used for many years [7]. A block diagram of such a system is given in Fig. 6. Without any input voltage (V_s) the VCO (voltage controlled oscillator) will generate a frequency related to the base frequency input (V_f). When a slot frequency is applied at V_s the signal is multiplied by the VCO signal to create a beat frequency. If the VCO frequency and the slot frequency are close enough, the beat frequency will be low enough to pass through the low pass filter and modify the VCO output. The VCO signal will continue to be modified until it locks onto the signal at V_s . The output voltage (V_{out}) is always directly related to VCO frequency and, under these conditions, would be related to the frequency at V_s .

The base frequency input (V_f) was chosen to be $(N_r + 1)$ times the stator frequency. Since this differs from the speed signal by only N_r times slip frequency, locking onto the signal was found to occur quite reliably.

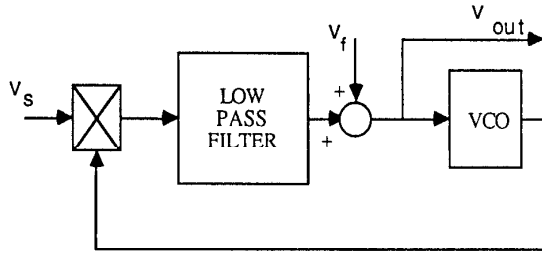

Fig. 6. Block diagram of frequency slaved loop circuit for detection of rotor slot harmonic frequencies.

When the circuit is locked the system can be described by the linear system shown in Fig. 7. The transfer function for this system is

$$\frac{\omega(s)}{\theta_r(s)} = \frac{s k_\phi k_f}{\tau s^2 + s + k_\phi k_f k_{vco}} \quad (6)$$

While the system response to changes in frequency will depend on the parameter settings, some important general observations can be made. For example, there is no steady state error for a step change in speed. When choosing the parameters to control the transient response the the lock-in frequency range, the hold-in frequency range, and transient limits must also be considered.

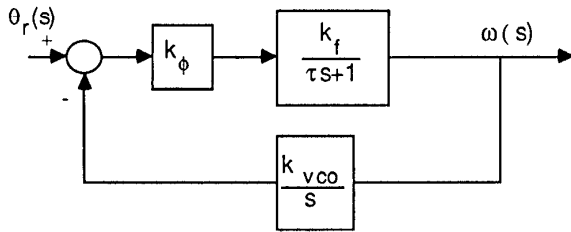

Fig. 7. Linearized equivalent for frequency slaved loop circuit.

The hold-in range is the span of frequencies from the base frequency setting (V_f) to the frequency where the FSL will remain locked after having been initially locked (see Fig. 8). This can be shown to be the range in which the steady state phase error remains linearly continuous [9]. This can be approximated as

$$\omega_H = k_f k_\phi k_{vco} \quad (7)$$

The lock-in range is the span of frequencies from the center frequency to the frequency where the system will initially lock (see Fig. 8). This frequency can be shown to be given by

$$\omega_L \cong \sqrt{\frac{k_\phi k_f k_{vco}}{\tau}} \quad (8)$$

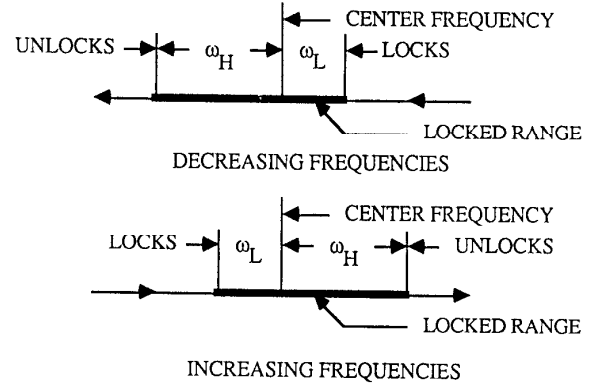

Fig. 8. Important frequencies for frequency slaved loop.

Practically the center frequency needs to be filtered to eliminate ripple frequencies in the calculated synchronous frequency. These ripples are caused by noise and offsets in the flux readings used in the frequency calculations. Without this filter the FSL locks only in ideal circumstances. The filter, however, causes the center frequency for the FSL to lag behind the desired center frequency. If this lag is large enough the system can move beyond the hold-in limit and become unlocked. For a first order low pass filter with a filter time constant of τ_f the acceleration limit becomes

$$\dot{\omega} = \frac{k_\phi k_f k_{vco}}{\tau_f} - \frac{\omega_H}{\tau_f} \quad (9)$$

The choice of lock-in and hold-in frequencies will therefore have a major effect on the acceleration rate. The lock-in range is usually small to help prevent locking on undesired signals. The hold-in range is also fairly small to keep the system relatively well damped. This defines a limit on the rate of acceleration of the machine.

EXPERIMENTAL RESULTS

A speed control system was implemented using the flux ripple detection scheme described. The system, as shown in the block diagram of Fig. 9, is built around a field oriented control (FOC) implemented on an IBM/AT. Experiments were performed to investigate the system behavior for both steady state and transient operating conditions.

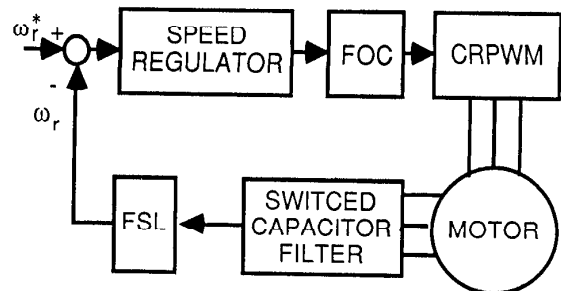

Fig. 9. Block diagram of speed control system.

Steady State Operation

The steady state operation of the FSL system was determined for both the straight and skewed rotor slot motors by measuring the speed under different load torques for different speed commands. An example of the speed-torque relationship for a frequency command near the middle of the operating range is shown in Fig. 10. The FSL system with both the skewed and straight rotor slots show little change in speed until the current limit of the inverter takes precedence around full load. In comparison a frequency control system shows a gradual decrease in speed as torque is increased. The commanded operating point for each condition varied slightly because of hardware and software adjustments.

The overall range in which the system has good speed regulation is shown in fig. 11. For this figure good speed regulation was defined as a speed droop from no load to full load of less than 5.5 RPM with a standard deviation of less than 3 RPM and no noticeable speed transients. The system was limited at high speeds because of a voltage limit on the drive. At high torques the system was limited by the current capability of the drive. At low speeds the steady state operation is limited because the slot ripple signal is reduced making it difficult to get a reliable speed signal. This is especially true at light loads when the rotor current is small.

For the most part there was little difference in the operation area between the unskewed and skewed rotor machines. The unskewed rotor was, however, able to regulate at speeds approximately 50 RPM less than the skewed rotor thus adding to the overall operating range. Also with the unskewed rotor the boundaries for the regulation region are more regular creating a more definite boundary for the regulation limit.

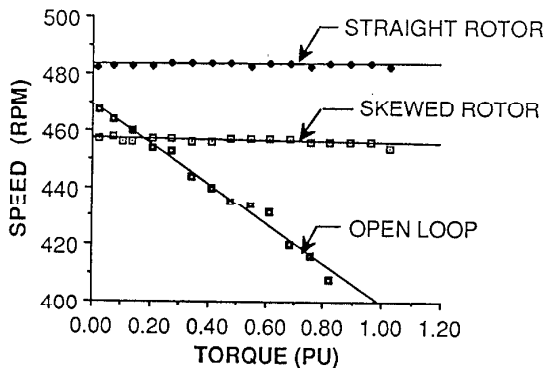

Fig. 10. Speed-torque relationships for a FSL system with a speed command near the middle of its operating range

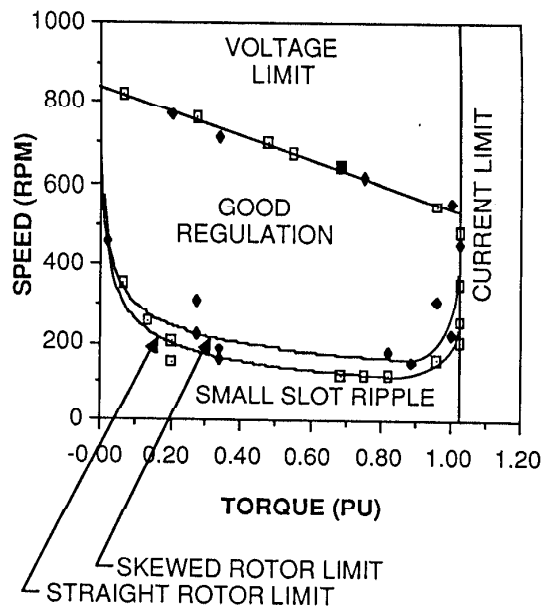

Fig. 11. Steady state operating range for FSL system.

Transient Operation

One method of examining the overall system performance is to study the response of the system to a step in speed command. Typically the response to a small step in speed command was found to be acceptable as shown in Fig. 12. The behavior is essentially that of a linear system and by adjusting system gains trade-offs can be made between rise time and overshoot.

For larger changes in speed command nonlinearities in the system become limiting factors in the response. One serious limitation is that the frequency slave loop output lags behind the actual speed rise. This lag exists because the frequency supplied to the FSL is highly filtered to eliminate noise problems. Because of this lag, there is a

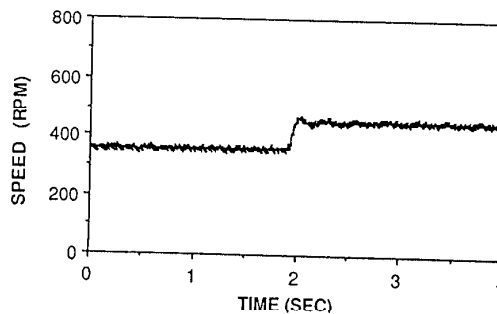

Fig. 12. Response to a small step in speed for the system with low gain settings.

considerable overshoot in the system response to a large change in speed command. An example of this overshoot is shown in fig. 13. To reduce this lag the bandwidth of the filter in the base frequency of the FSL could be increased. When this bandwidth is increased the overshoot is considerably reduced as seen in Fig. 14. Because of the additional noise on the base frequency, however, the FSL has more difficulty locking onto the slot ripple seriously degrading its steady state performance.

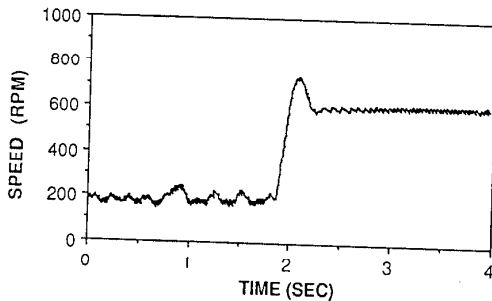

Fig. 13. Speed response for a large step in speed command.

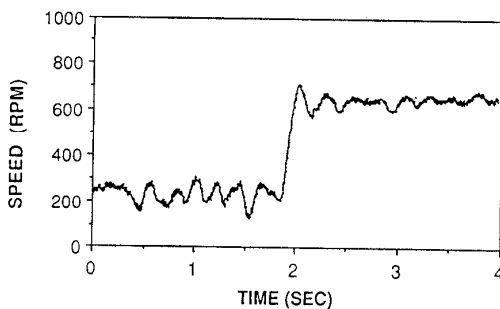

Fig. 14. Speed response for a large step in speed command with wide bandwidth in base frequency filter.

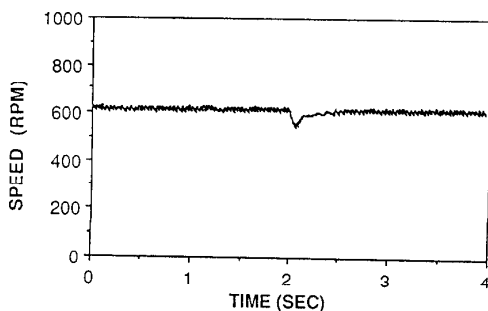

Fig. 15. Speed response to a 0.5 PU step increase in load.

For a typical speed control application it is important to have good speed regulation under torque load disturbances. Figure 15 shows the system response for a large step change of half the rated load. Initially the speed drops about 10% but recovers in 500 msec. This response is far from servo grade performance but is reasonable for moderate performance applications.

CONCLUSION

Speed information is available from stator winding voltages using a system that includes a switched capacitor filter and a frequency slaved loop. With this speed information a speed control system can be built without the use of a tachometer. Although the speed regulator developed was limited in its operating range and showed only moderate performance such a system could be used in many applications where high performance is not required. It was also found that some improvements can be made by using a machine with unskewed rotor bars instead of the conventional skewed rotor.

REFERENCES

- [1] R. Joetten and G. Maeder, 'Control Methods for Good Dynamic Performance Induction Motor Drives Based on Current and Voltage as Measured Quantities,' in *Proceedings of International Semiconductor Power Conversion Conference*, 1982 pp. 397-403
- [2] M. Ishida and K. Iwata, 'New Slip Frequency Detector of an Induction Motor Utilizing Rotor Slot Harmonics,' in *Proceedings of the International Semiconductor Power Conversion Conference*, 1982, pp. 408-415
- [3] M. Ishida, K. Hayashi, and M. Ueda, 'A Speed Detection Method of Squirrel-Cage Induction Motor Utilizing Rotor Slot Harmonics in Air Gap and Its Application to Slip Frequency Control,' *Electrical Engineering in Japan*, Vol. 90, No. 3, pp. 74,84, 1979
- [4] T. A. Lipo and K. C. Chang, 'A New Approach to Flux and Torque Sensing of Induction Machines,' *IEEE Transactions on Industry Applications*, Vol. IA-22, No. 4, pp. 731-737, July/Aug 1986.
- [5] D. Zinger, F. Profumo, T. A. Lipo, and D. W. Novotny, 'A Direct Field Oriented Controller for Induction Drives Using Tapped Stator Windings,' in *PESC '88 Record*, 1988, pp. 855-861.
- [6] B. J. Hasticka, R. W. Broderso, and P. R. Gray, 'MOS Sampled Data Recursive Filters Using Switched Capacitor Integrators,' *IEEE Journal of Solid State Circuits*, vol. SC-12, No. 6, pp. 600-608, Dec. 1977.
- [7] C. M. Chie and W. C. Lindsey, eds., *Phase Locked Loops*, New York: IEEE Press, 1986.
- [8] P. L. Alger, *Induction Machines*: New York: Gordon and Breach, 1970.
- [9] Gardner, *Phaselock Techniques*: John Wiley and Sons, 1966.