

Wisconsin Electric Machines and Power Electronics Consortium

RESEARCH REPORT
90-3

A NEW ENERGY RECOVERY SCHEME FOR DOUBLY FED,
VARIABLE SPEED INDUCTION MOTOR DRIVES

Liao Fan, Sheng Ji, and T.A. Lipo
Dept. of Elec. and Comp. Eng.
University of Wisconsin-Madison
1415 Johnson Drive
Madison, WI 53706-1691

WEMPEC

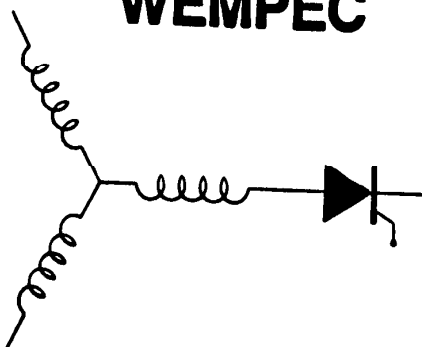

Department of Electrical and Computer Engineering
1415 Johnson Drive
Madison, Wisconsin 53706

© February 1990 Confidential

A New Energy Recovery Scheme for Doubly Fed, Variable Speed Induction Motor Drives

Liao Fan, Sheng Ji and T.A. Lipo
 Department of Electrical and Computer Engineering
 University of Wisconsin-Madison
 1415 Johnson Drive
 Madison, WI 53706, USA

Abstract: Speed control of wound rotor induction motors with slip-power feedback to the supply utilizing a converter cascade is used in many industrial applications requiring high power over a relatively narrow speed range. As the rotor voltage is typically lower than the supply voltage due to the narrow range of slip frequency, a step-up transformer must be inserted between the inverter and supply in order to improve power factor and reduce line harmonics. In this paper, a new concept is presented which eliminates the need for the transformer by feeding back slip power to the stator winding directly. The selection of feedback point on the stator winding, the equivalent circuit and the main parameters of this system are discussed. Test results on a wound rotor induction motor are shown which indicate that this system also has acceptable performance in addition to its potential for lower cost.

Introduction

In recent years ac drive systems have been progressively used in a wide variety of industrial production and has assumed its place over dc drives as the drive system of choice. Among these ac systems, speed control of a wound rotor induction motor using a cascaded converter continues to find use in high power applications requiring a relatively narrow speed range. In general, most present day systems utilize the static Scherbius arrangement to feed back the slip power to the supply. Such systems provide both variable speed subsynchronous and supersynchronous operation. References [1-3] are representative of the two typical slip power feedback methods employed in recent years. As the rotor voltage is typically lower than the supply voltage due to the narrow range of slip frequency, a step-up transformer must be inserted between the inverter and supply in such schemes order to improve power factor and reduce the line harmonics. Clearly the elimination of this transformer would result in a substantial cost saving.

In reference [4] a feedback method is proposed which involves feeding the slip power to a separate auxiliary stator winding by using a transformer connected to the wound rotor. However, utilization of the machine was relatively poor due to the extra windings which must be installed in the machine. In addition, the presence of the transformer was not eliminated resulting in a more complicated and costly arrangement. As an alternative approach to recovering energy from the rotor under line (or natural) commutation, a new method is proposed in this paper whereby feedback of the slip power to the stator winding is done directly by means of taps on the stator windings. Hence, the stator functions as a type of autotransformer, converting power from the rotor through the stator back to the supply. The proper feedback point on the stator winding is determined from the open circuit voltage of the wound rotor and the projected speed control range.

In this paper the selection of feedback point on the stator winding, the equivalent circuit and the main parameters of this system are discussed. Test results on a wound rotor induction motor are shown which indicate that this system also has acceptable performance in addition to its potential for cost savings.

Principle of Operation

The design of a stator winding to achieve desirable characteristic for this machine is relatively straightforward. Thus, the need for a transformer can be eliminated and the drive system is markedly simplified. A circuit illustrating this concept is shown in Fig. 1. The concept of the energy feedback principle can be obtained from fundamental component, steady state considerations. From References [1-3] and Fig.1, the rectified no load dc link voltage is related to the rotor open circuit ac voltage by

$$V_{d0} = 2.34S V_{r0} \quad (1)$$

The voltage on the dc side of the inverter can be written,

$$V_{\alpha} = 2.34 V_{\phi} \cos \alpha \quad (2)$$

where V_{d0} = open circuit voltage of the dc link;
 S = per unit slip;
 V_{r0} = open rotor voltage per phase at locked rotor;
 V_{α} = average counter e.m.f. on the dc side of 3-phase bridge inverter;
 V_{ϕ} = ac voltage at the feedback point (see Fig. 1);
 α = firing angle, $\pi/2 \leq \alpha \leq \pi$.

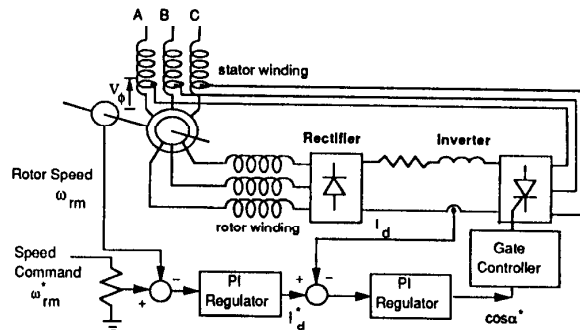

Fig.1 Variable speed doubly fed induction motor employing slip power feedback to stator winding taps.

It is clear that if $V_{d0} > V_{\alpha}$ (assuming that the overlap angle and resistance drop is neglected) then the rotor can deliver slip power to the stator winding.

In practice the maximum firing angle α_{max} must account for the turn-off time of the thyristor, the actual overlap angle γ and, in addition, includes a safety value to avoid failure during inversion. In general, α_{max} is about 150° to 155° .

Machine Construction and Control System

From above mentioned principle a new stator winding was designed from an existing 1.5 HP, 120 V, 6 pole, 60 Hz induction motor. The rated current of this machine is 7.6 Amps. In this new machine the wound rotor remains unchanged. Since the open circuit voltage (line to line) of this rotor was measured as 85 V, the feedback point was selected at the 1/4 point of the stator winding where the open circuit voltage corresponds to 30 V. In order to maintain phase balance, the stator was rewound as a lap wound machine with a phase belt of four coils. One of the four coils of each of the phase belts was connected in series to form the tap point on the machine.

The control system block diagram of the drive is also presented in Fig. 1. For the purpose of controlling the speed at any load, a straightforward double closed loop arrangement has been adopted. The commanded speed and the measured speed are summed, and then through the speed PI controller the error meets

the current feedback loop at a second summer. Finally, a PI current controller was used with the output passed to the firing controller to change the firing angle of thyristors with changes in load. In addition, not shown, are auxiliary means to limit the current during start up.

Test Results

The experimental wound rotor induction motor has been thoroughly tested under both the conventional Scherbius scheme and the tapped stator winding arrangement. Figure 2 shows torque versus speed curves for the tapped winding approach using the inverter phase delay angle α as a parameter. Note that the entire torque speed curve can be shifted to lower speeds in much the same manner as the Scherbius system. Figure 3 shows how torque varies with input power at two selected phase delay angles. In Figure 4 is plotted the corresponding system efficiency. It can be observed that when the input power is identical, the output torque and the efficiency for the two feedback techniques are essentially the same. Hence, elimination of the step transformer to the supply can be eliminated without appreciable deterioration of performance. Figure 4 also demonstrates that the efficiency of the motor in normal situation (shorted rotor) is very poor in comparison to both feedback techniques as expected. In Fig. 5 is shown the displacement power factor for the same two selected phase delay angles plotted as a function of per unit slip. It is very interesting to observe that for the case of feedback to the stator winding, the displacement power factor ($\cos\phi$) in the portions of the stator winding at lower potential (i.e. the "low potential stator winding") and at higher potential (i.e. the "high potential stator winding") are very different from each other. This result occurs since the current flowing to the low potential stator winding from the inverter are very nearly in phase. It can be observed, however, that the net power factor measured at the supply input remains almost the same for the two feedback methods. In the experimental system the total displacement power factor using feedback to the supply was actually slightly higher than with feedback to stator winding taps.

Figures 6 and 7 compare input power for the two schemes for typical operating conditions corresponding to $\alpha = 142.2^\circ$. In Fig. 6 corresponding to the Scherbius connection, note the relatively high value of input power to the stator winding. Since all of the power, including the power fed back to the supply, passes through the stator winding, the corresponding stator I^2R are correspondingly high. In Fig. 7 the measured power for the new tapped stator winding configuration is shown. In this case the total power fed to the stator winding corresponds to the power arriving from the stator terminal, P_{in} , plus the power fed back from the rotor, P_r . The sum of these power are indicated by a dashed line in Fig. 7. The power absorbed by the stator can be segregated into two parts corresponding to the power in the high potential stator winding and the low potential stator winding. The power

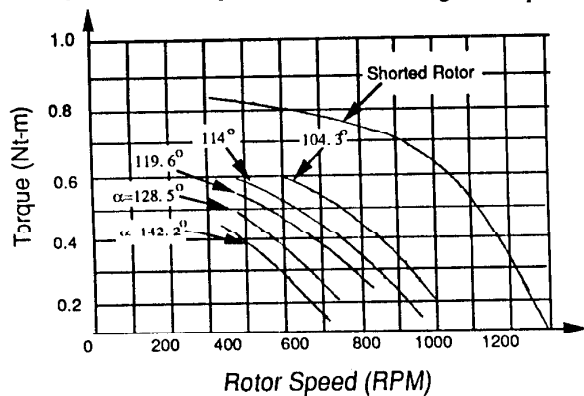

Fig.2 Torque versus speed characteristics as a function of the inverter delay angle α .

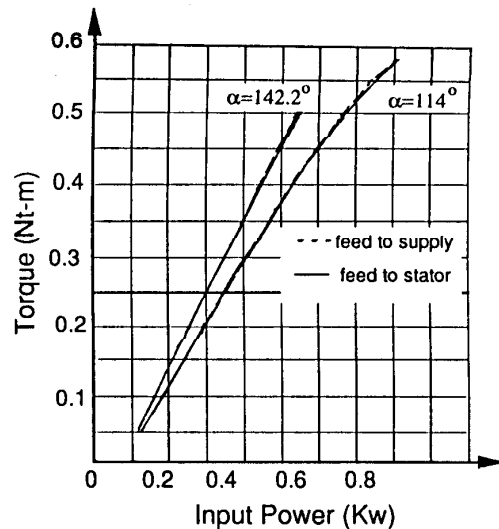

Fig.3 Torque versus input power for two different inverter delay angles α showing comparison of feedback method with stator taps with Scherbius arrangement (feed back to the supply).

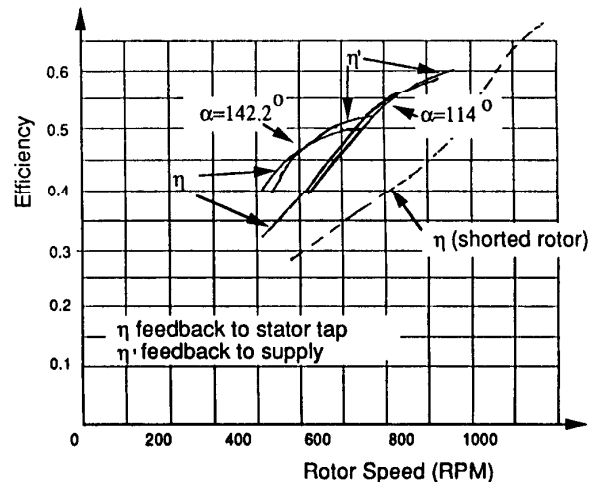

Fig. 4 Efficiency versus input power for two different inverter delay angles α showing comparison of feedback method using stator windings taps with the Scherbius arrangement.

consumed by the two portions of the stator winding are indicated by braces in Fig. 7. Note that the power absorbed by the low potential stator winding takes a proportionately larger amount of power than the high potential stator winding. Figure 7 indicates that the power flowing into the low potential stator winding having only 1/4 the total stator turns is nearly 1/2 the total input power of the motor. Hence the current $I_{s(low)}$ is higher than current $I_{s(high)}$ as shown in Fig. 8. In comparison with the Scherbius arrangement, $I_{s(high)}$ is less than the stator current for the case of the Scherbius machine. The overall result is an efficiency in energy conversion for the two machines being nearly equal as shown in Fig. 4. Clearly, the efficiency of the tapped winding machine construction could be considerably improved by altering the cross sectional areas of the low potential and high potential stator winding portions to be more compatible with the different values of current in the two portions of the winding. In this case,

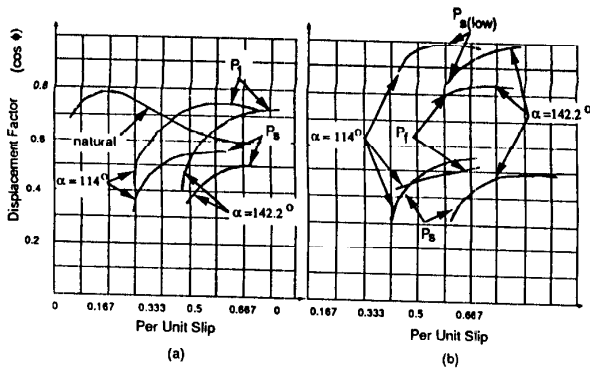

Fig.5 Fundamental component power factor $\cos\phi$ as a function of per unit slip. (a) Scherbius arrangement with slip power fed back to the supply, (b) new arrangement with slip power fed back to taps on the stator winding.

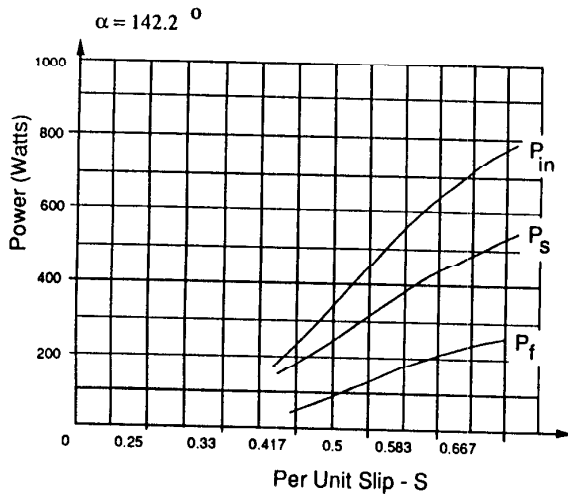

Fig.6 Power measured at various points plotted versus per unit slip for the Scherbius arrangement. P_s : power fed to the stator windings. P_f : power fed back to the supply, P_{in} : total input power. (b)

efficiencies could be expected to exceed the Scherbius arrangement. Oscillograms of various currents are shown in Figs. 9 and 10 for the two feedback techniques. It can be observed that the supply current, rotor current and the inverter feedback current have nearly the same wave forms. The current $I_{s(low)}$ flowing in the low potential stator winding has slightly more harmonic content than the current I_s flowing in the stator of the Scherbius machine since the additional transformer acts to filter a portion of the harmonics.

Figure 11 indicates that at a selected stator/rotor turns ratio of the motor tap position and at a fixed firing angle, the slip power only can feed to the stator winding at slips higher than a certain value, S_{min} . When the slip is lower than S_{min} the dc link voltage V_{do} is too low to deliver power to the stator. In the 1.5 HP experimental motor used in this study the feedback range and the limited slip S line are shown in Fig. 11. The characteristic indicates the need to carefully select the turns ratio and tap position for a given variable speed application.

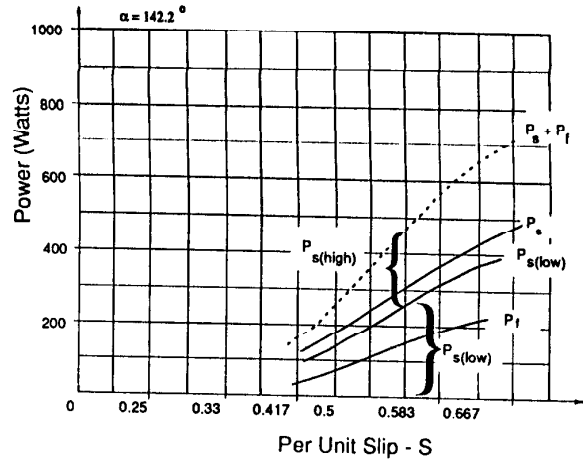

Fig. 7 Power measured at various points for inverter delay angle $\alpha = 142.2^\circ$ plotted versus per unit slip for the new arrangement with slip power fed back to taps on the stator winding. P_s : total power fed to the stator windings, $P_{s(low)}$: power fed to the portion of stator winding at lower potential than the taps, $P_{s(high)}$: power absorbed by portion of stator winding at potential higher than the stator taps, P_f : power fed back to the stator winding via taps, $P_s + P_f$: total power fed to the stator winding, P_{in} : total input power.

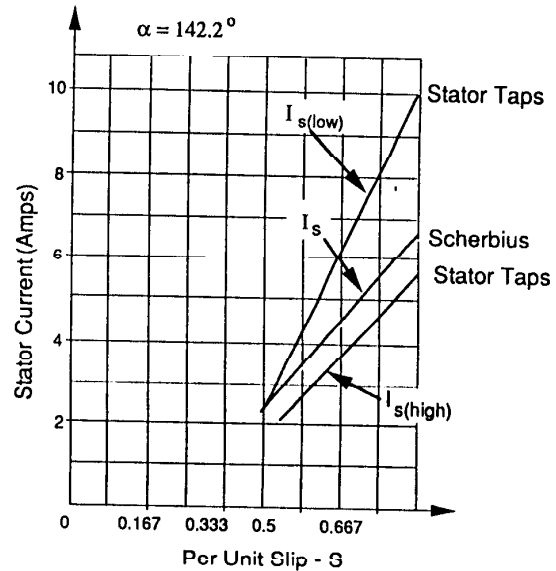
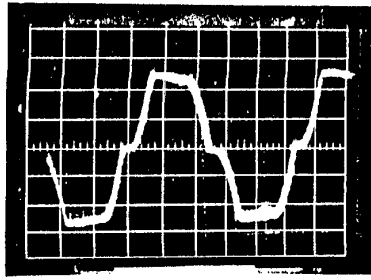
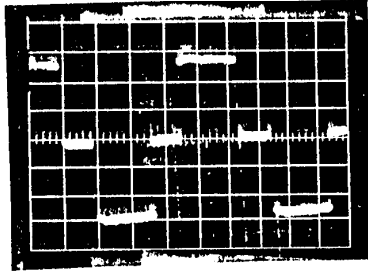

Fig. 8 Comparison of current in high potential and low potential portions of stator winding for new arrangement with the stator current in winding of machine with Scherbius connection. Inverter phase delay angle $\alpha = 142.2^\circ$.



(a)



(b)

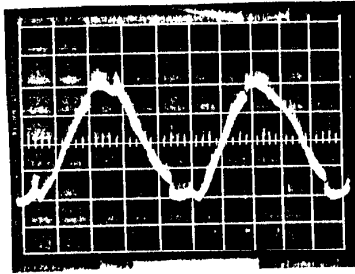

(c)

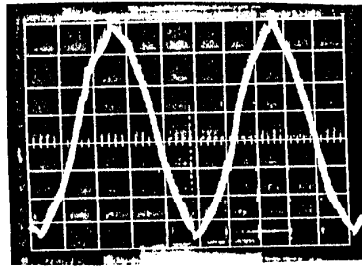

(d)

Fig. 9 Oscillograms of system currents for Scherbius connection. (a) Rotor current (rectifier ac current) i_r , (b) Feed back current (inverter ac current) i_f , (c) Stator Current i_s , (d) Supply current i_{in} .

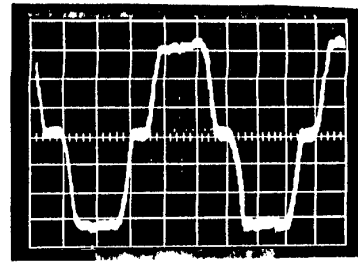

(a)

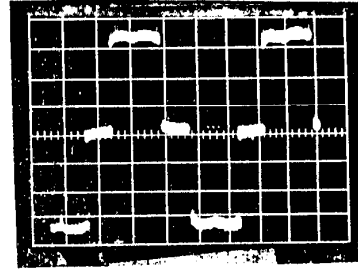

(b)

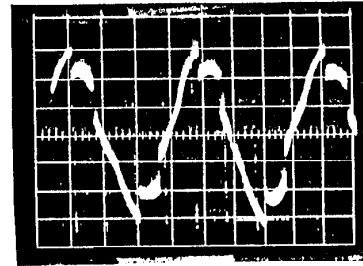

(c)

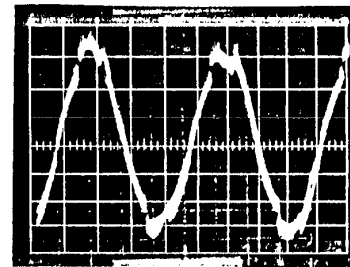

(d)

Fig. 10 Oscillograms of system currents for feedback arrangement using stator winding taps. (a) Rotor current (rectifier ac current) i_r , (b) Feed back current (inverter ac current) i_f , (c) Current in low potential portion of stator winding $i_{s(low)}$, (d) Current in high potential portion of stator winding (supply current) $i_{s(high)} = i_{in}$

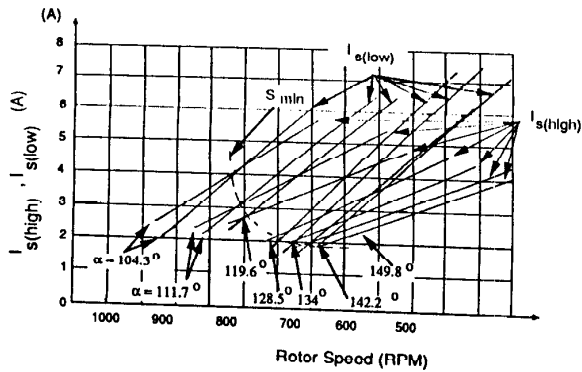

Fig. 11 Currents in the high and low potential portions of the stator windings versus speed for different inverter firing angles α . Dashed line shows the commutation limit imposed by insufficient dc link voltage.

Conclusion

A new speed control scheme for a wound rotor induction motor utilizing feed back of the slip power to the stator winding by means of taps. It is shown that with this feedback system, the motor can be operated over a very wide range even to slips reaching 0.75. As compared with the feedback slip power to the supply system, performance parameters such as the torque-speed profiles, efficiency and the power factor are almost keep the same as the Scherbius arrangement. Thus, the need for a transformer between the inverter and the power mains can be eliminated resulting in a simplification and cost reduction of the electrical circuit.

In order to maintain the power factor of this system at a highest value, the inverter firing angle should be a maximum value at the lowest controllable speed. Thus, the rotor voltage at the maximum slip S_{max} should be approximately equal to the feedback point voltage of the stator winding. In the machine studied, the motor was equipped with four coils in each phase belt and the tap was located at the 1/4 potential point. Other tap locations could prove to be optimum and no analysis was carried out to determine the optimum for a given speed range. An analysis of this type could be the topic of a future paper. Other voltage tap points could be obtained by varying the number of turns per coil of the coil in the phase belt and/or altering the number of effective rotor turns. Since the currents which flow in the two portions of the stator winding are unequal it may be convenient to rearrange the stator winding turns distribution to improve the symmetry of the MMF. Since that, the performance of the motor also can be improved.

It has been shown that the efficiency of the proposed slip power feedback scheme decreases at higher slip in the same manner as the Scherbius arrangement. The optimum range of the speed control appears to 2:1 or 2.5:1. However, in contrast the the Scherbius method, several taps might be considered to improved the overall performance over a wide speed range.

References

- [1] A. Lavi and R.J. Poige, "Induction Motor Speed Control with Static Inverter in the Rotor", IEEE Trans.on Power Apparatus and Systems, No. 1, 1966.
- [2] M. S. Erlicki, "Inverter Rotor Drive of an Induction Motor", IEEE Trans. on Power Apparatus and Systems, No. 11, 1965.
- [3] A. Gordon, "A Current-Source Inverter in the Secondary Circuit of a Wound Rotor Induction Motor Provides Sub-and Supersynchronous Operation", IEEE Trans.on Industry Applications, No. 4, 1981.

- [4] W. Shepherd and J. Stanway, "Slip Power Recovery in an Induction Motor by the Use of a Thyristor Inverter", IEEE Trans.on Industry Applications, No.1, 1969.
- [5] M. Sakui and H. Fujita, "A Simplified Steady State Analysis by Equivalent Circuit Method of Induction Motor with a Rectifier in Rotor Circuit", Electrical Engineering in Japan, No. 6, 1980.
- [6] T.A.Lipo and D.W.Novotny, "Dynamics and Control of AC Drives", Class Notes, University of Wisconsin, 1986.