

# Wisconsin Electric Machines and Power Electronics Consortium

RESEARCH REPORT  
91-21

dq Modeling of Five Phase Synchronous Reluctance Machines Including Third  
Harmonic of Air-Gap MMF

Hamid A. Toliyat, Mina A. Rahimian, Thomas A. Lipo  
University of Wisconsin-Madison  
1415 Johnson Drive  
Madison, WI 53706

**WEMPEC**

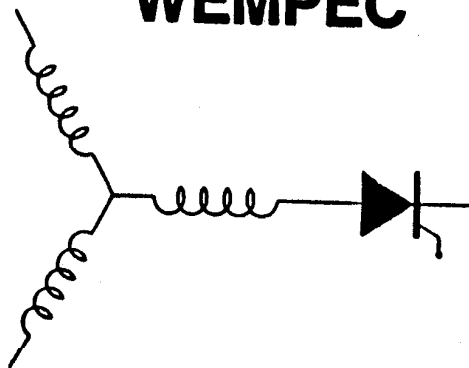

Department of Electrical and Computer Engineering  
1415 Johnson Drive  
Madison, Wisconsin 53706

# dq Modeling of Five Phase Synchronous Reluctance Machines Including Third Harmonic of Air-Gap MMF

Hamid A. Toliyat  
Member, IEEE

Mina M. Rahimian  
Non Member

Thomas A. Lipo  
Fellow, IEEE

University of Wisconsin-Madison  
1415 Johnson Drive  
Madison, WI 53705

**Abstract** - In this paper a detailed analysis and development of the dq equations for a five phase synchronous reluctance machines including the third harmonic of the air-gap are presented. They are compared with the equations in the natural system (abc), already given in [1]. Simulation traces are used to confirm the model. Finally, the developed equations are compared to the experimental results and the similarities and discrepancies identified.

## 1. Introduction

In traditional machine applications, three phases are normally selected since this typically results in the lowest transmission cost. However, when the machine is connected to an inverter supply the need for a specific number of phases, such as three, disappears, and other phase numbers can be chosen. For example, in large machines two pairs of three phase windings shifted by 30 electrical degrees have found favor [1]. In a recent paper [2] the benefits of five phases have been recognized. In particular, it was determined that whereas three phase machines can utilize only the fundamental component to develop torque, torque can be developed by both the first and the third harmonic in a five phase machine [3,4,5]. By extension, seven phase machines can be controlled to utilize the first, third and fifth harmonics for torque production and so forth. In this paper, it is shown that the classical d-q analysis can be extended to such machines. In particular, the case of a five phase reluctance machine has been chosen for analysis but the approach can be extended to higher order phase number. The set of voltage equations developed are sufficiently detailed to describe both the transient and steady state behavior of a five phase synchronous reluctance machine.

## 2. System Equations

Let us consider the idealized representation of a five phase, 2 pole reluctance motor as shown in Figure 2-1. The winding axes of the five stator windings are displaced by 72°. Saturation of iron will be neglected in this analysis. Although the machine is assumed to have only 2 poles, the effects of multiple poles can be readily included when it becomes necessary by traditional methods.

It is convenient to denote each physical winding by an equivalent coil aligned along the point of maximum MMF produced by each winding. It is assumed initially that none of the circuits are physically interconnected. In general, the equation which describe the electrical behavior of this machine in matrix form is

$$\mathbf{V}_s = \mathbf{R}_s \mathbf{I}_s + \frac{d\Lambda_s}{dt} \tag{2-1}$$

where

$$\Lambda_s = \mathbf{L}_{ss} \mathbf{I}_s \tag{2-2}$$

and corresponds to the flux linkages of the windings, and where

$$\mathbf{I}_s = \begin{pmatrix} i_a^s & i_b^s & \dots & i_e^s \end{pmatrix}^t \tag{2-3}$$

$$\mathbf{V}_s = \begin{pmatrix} v_a^s & v_b^s & \dots & v_e^s \end{pmatrix}^t \tag{2-5}$$

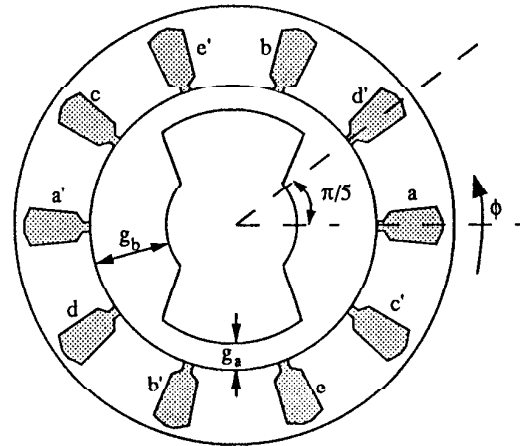

Figure 2-1 Synchronous Reluctance Motor with Two Pole, Five Phase Concentrated Windings.

The matrix  $\mathbf{R}_s$  is a diagonal 5 by 5 matrix given by

$$\mathbf{R}_s = r_s \mathbf{I} \tag{2-6}$$

where the matrix  $\mathbf{I}$  is a 5 by 5 identity matrix and  $r_s$  is the resistance of each coil assuming all coils are similar.

The matrix  $L_{ss}$  due to conservation of energy is a symmetric 5 by 5 matrix of the form

$$L_{ss} = \begin{pmatrix} L_{aa}^s & L_{ab}^s & \dots & L_{ac}^s \\ L_{ab}^s & L_{bb}^s & \dots & L_{bc}^s \\ \vdots & \vdots & \dots & \vdots \\ L_{ac}^s & L_{bc}^s & \dots & L_{cc}^s \end{pmatrix} \quad (2-7)$$

where the diagonal elements are the self inductances of each of the phases including both leakage and magnetizing components. The off-diagonal entries are the mutual inductances between each pair of phases.

### 3. Stator Inductances

The axis of phase *a* is used as the reference point for the circumferential angle  $\phi$  used to define the winding function  $N(\phi)$  in Fig. 3-1 [6]. In general the winding function is a stepped-like function due to the discrete nature of the winding slots. In the so-called sinusoidally wound machines, the low order harmonic components of the winding function for each phase are small relative to the fundamental component. However, in case of a concentrated winding machine, the third harmonic of the winding function for each phase is specifically not negligible and therefore the effect of third harmonic must be considered in the winding functions.

Notice that the incorporation of the third harmonic for the stator winding function is a necessary condition for existence of linkage of the air-gap flux third harmonic component with the stator phase windings. Without this term the third harmonic of air-gap flux would not link the stator winding. Assuming that only the fundamental and third harmonic components are significant, the winding functions of the five stator windings can then be expressed

$$N_a(\phi) = \frac{4N}{\pi} \left( \cos \phi - \frac{1}{3} \cos 3\phi \right) \quad (3-1)$$

$$N_b(\phi) = \frac{4N}{\pi} \left( \cos \left( \phi - \frac{2\pi}{5} \right) - \frac{1}{3} \cos 3 \left( \phi - \frac{2\pi}{5} \right) \right)$$

$$N_c(\phi) = \frac{4N}{\pi} \left( \cos \left( \phi - \frac{4\pi}{5} \right) - \frac{1}{3} \cos 3 \left( \phi - \frac{4\pi}{5} \right) \right)$$

$$N_d(\phi) = \frac{4N}{\pi} \left( \cos \left( \phi + \frac{4\pi}{5} \right) - \frac{1}{3} \cos 3 \left( \phi + \frac{4\pi}{5} \right) \right)$$

$$N_e(\phi) = \frac{4N}{\pi} \left( \cos \left( \phi + \frac{2\pi}{5} \right) - \frac{1}{3} \cos 3 \left( \phi + \frac{2\pi}{5} \right) \right)$$

where  $N$  is the number of turns per pole per phase. In order to calculate the winding inductances, the flux linkages arising either from the winding itself or another winding must be computed.

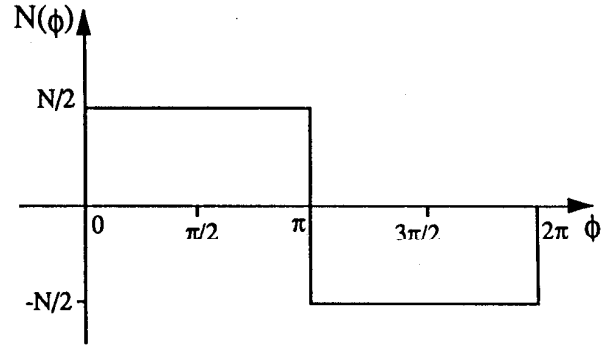

Figure 3-1 Winding Function for Each Phase of the Five Phase Synchronous Reluctance Machine.

Due to the saliency of the rotor, the air gap is not constant as for the case of an induction motor but is a function of spatial angle  $\phi$ . With the aid of flux plots the gap length  $g$  can be measured as a function of  $\phi$ . For this analysis it is assumed that an inverse air-gap function is defined as given by Figure 3-2. In practical cases the rotor is designed to have an even number of symmetrically shaped poles and an equal number of north and south poles. Therefore, the inverse gap function consists of a constant term plus even harmonics. Assuming  $\tau_p$  is the rotor pole arc, the gap function is

$$g^{-1}(\phi - \theta) = a - \frac{2b}{k} \sin \frac{k\tau_p}{2} \cos k(\phi - \theta) \quad ; k=2,4,6, \dots$$

where

$$a = \frac{1}{2} \left( \frac{1}{g_a} + \frac{1}{g_b} \right)$$

$$b = -\frac{2}{\pi} \left( \frac{1}{g_a} - \frac{1}{g_b} \right)$$

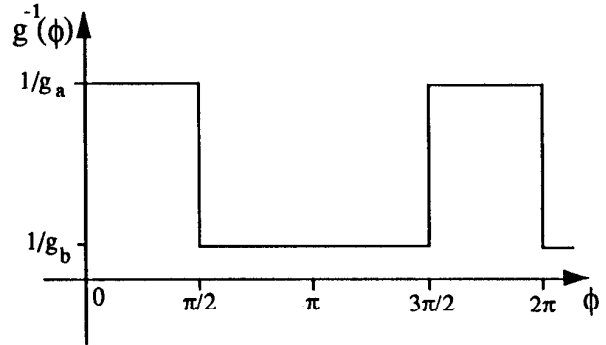

Figure 3-2 Inverse Air-gap Function for a Synchronous Reluctance Machine.

In this analysis up to the third term is considered to include the effect of third harmonic of MMF. Therefore the inverse gap function for  $\tau_p = 90^\circ$  is

$$g^{-1}(\phi - \theta) = a - b \cos 2(\phi - \theta) + \frac{b}{3} \cos 6(\phi - \theta) \quad (3-2)$$

and  $g_a$  and  $g_b$  are the minimum and maximum air-gap respectively. Using the method presented in [2,6], the self inductances are readily calculated and presented here for future reference.

$$L_{aa} = I_{1a} + K \left( \frac{10\pi a}{9} - \frac{\pi b}{6} \cos 2\theta + \frac{\pi b}{54} \cos 6\theta \right) \quad (3-3)$$

$$L_{bb} = I_{1b} + K \left( \frac{10\pi a}{9} - \frac{\pi b}{6} \cos 2(\theta - \frac{2\pi}{5}) + \frac{\pi b}{54} \cos 6(\theta - \frac{2\pi}{5}) \right)$$

$$L_{cc} = I_{1c} + K \left( \frac{10\pi a}{9} - \frac{\pi b}{6} \cos 2(\theta - \frac{4\pi}{5}) + \frac{\pi b}{54} \cos 6(\theta - \frac{4\pi}{5}) \right)$$

$$L_{dd} = I_{1d} + K \left( \frac{10\pi a}{9} - \frac{\pi b}{6} \cos 2(\theta + \frac{4\pi}{5}) + \frac{\pi b}{54} \cos 6(\theta + \frac{4\pi}{5}) \right)$$

$$L_{ee} = I_{1e} + K \left( \frac{10\pi a}{9} - \frac{\pi b}{6} \cos 2(\theta + \frac{2\pi}{5}) + \frac{\pi b}{54} \cos 6(\theta + \frac{2\pi}{5}) \right)$$

where

$$K = \mu_0 r l \frac{4N^2}{\pi^2} \quad (3-4)$$

with  $r$  being the stator inner radius and  $l$  the effective stator stack length.  $L_{1a}, \dots, L_{1e}$  are the leakage inductances of each phase which are generally equal.

Similarly the mutual inductances are

$$L_{ab} = K \left[ \pi a \left[ \cos \frac{2\pi}{5} + \frac{1}{9} \cos \frac{4\pi}{5} \right] - \frac{\pi b}{6} \left[ -2 \cos \frac{4\pi}{5} + 3 \right] \right. \\ \left. \cos 2(\theta + \frac{4\pi}{5}) + \frac{\pi b}{54} \cos 6(\theta + \frac{4\pi}{5}) \right] \quad (3-5)$$

$$L_{ac} = K \left[ \pi a \left[ \cos \frac{4\pi}{5} + \frac{1}{9} \cos \frac{2\pi}{5} \right] - \frac{\pi b}{6} \left[ -2 \cos \frac{2\pi}{5} + 3 \right] \right. \\ \left. \cos 2(\theta - \frac{4\pi}{5}) + \frac{\pi b}{54} \cos 6(\theta - \frac{2\pi}{5}) \right]$$

$$L_{ad} = K \left[ \pi a \left[ \cos \frac{4\pi}{5} + \frac{1}{9} \cos \frac{2\pi}{5} \right] - \frac{\pi b}{6} \left[ -2 \cos \frac{2\pi}{5} + 3 \right] \right. \\ \left. \cos 2(\theta + \frac{2\pi}{5}) + \frac{\pi b}{54} \cos 6(\theta + \frac{2\pi}{5}) \right]$$

$$L_{ae} = K \left[ \pi a \left[ \cos \frac{2\pi}{5} + \frac{1}{9} \cos \frac{4\pi}{5} \right] - \frac{\pi b}{6} \left[ -2 \cos \frac{4\pi}{5} + 3 \right] \right. \\ \left. \cos 2(\theta - \frac{4\pi}{5}) + \frac{\pi b}{54} \cos 6(\theta - \frac{4\pi}{5}) \right]$$

$$L_{bc} = K \left[ \pi a \left[ \cos \frac{2\pi}{5} + \frac{1}{9} \cos \frac{4\pi}{5} \right] - \frac{\pi b}{6} \left[ -2 \cos \frac{4\pi}{5} + 3 \right] \right. \\ \left. \cos 2(\theta + \frac{2\pi}{5}) + \frac{\pi b}{54} \cos 6(\theta + \frac{2\pi}{5}) \right]$$

$$L_{bd} = K \left[ \pi a \left[ \cos \frac{4\pi}{5} + \frac{1}{9} \cos \frac{2\pi}{5} \right] - \frac{\pi b}{6} \left[ -2 \cos \frac{2\pi}{5} + 3 \right] \right. \\ \left. \cos 2(\theta - \frac{4\pi}{5}) + \frac{\pi b}{54} \cos 6(\theta - \frac{4\pi}{5}) \right]$$

$$L_{be} = K \left[ \pi a \left[ \cos \frac{4\pi}{5} + \frac{1}{9} \cos \frac{2\pi}{5} \right] - \frac{\pi b}{6} \left[ -2 \cos \frac{2\pi}{5} + 3 \right] \right. \\ \left. \cos 2\theta + \frac{\pi b}{54} \cos 6\theta \right]$$

$$L_{cd} = K \left[ \pi a \left[ \cos \frac{2\pi}{5} + \frac{1}{9} \cos \frac{4\pi}{5} \right] - \frac{\pi b}{6} \left[ -2 \cos \frac{4\pi}{5} + 3 \right] \right. \\ \left. \cos 2\theta + \frac{\pi b}{54} \cos 6\theta \right]$$

$$L_{ce} = K \left[ \pi a \left[ \cos \frac{4\pi}{5} + \frac{1}{9} \cos \frac{2\pi}{5} \right] - \frac{\pi b}{6} \left[ -2 \cos \frac{2\pi}{5} + 3 \right] \right. \\ \left. \cos 2(\theta + \frac{4\pi}{5}) + \frac{\pi b}{54} \cos 6(\theta + \frac{4\pi}{5}) \right]$$

$$L_{de} = K \left[ \pi a \left[ \cos \frac{2\pi}{5} + \frac{1}{9} \cos \frac{4\pi}{5} \right] - \frac{\pi b}{6} \left[ -2 \cos \frac{4\pi}{5} + 3 \right] \right. \\ \left. \cos 2(\theta - \frac{2\pi}{5}) + \frac{\pi b}{54} \cos 6(\theta - \frac{2\pi}{5}) \right]$$

#### 4. Stator Voltage Equations

Since the inductance matrix  $L_{ss}$  varies with the position of the rotor, the second term of equation (2-1) can be written as

$$\frac{d\Lambda_s}{dt} = L_{ss} \frac{dI_s}{dt} + \frac{dL_{ss}}{dt} I_s \quad (4-1)$$

The second term in the above equation can be written using the chain rule as

$$\frac{dL_{ss}}{dt} I_s = \frac{dL_{ss}}{d\theta_{rm}} \frac{d\theta_{rm}}{dt} I_s \quad (4-2)$$

Defining rotor mechanical speed as

$$\omega_{rm} = \frac{d\theta_{rm}}{dt} \quad (4-3)$$

then

$$\frac{dL_{ss}}{dt} I_s = \omega_{rm} \frac{dL_{ss}}{d\theta_{rm}} I_s \quad (4-4)$$

Therefore, Eq. (4-1) can typically be written in the form,

$$\frac{d\Lambda_s}{dt} = L_{ss} \frac{dI_s}{dt} + \omega_{rm} \frac{dL_{ss}}{d\theta_{rm}} I_s \quad (4-5)$$

Substituting equation (4-5) in (2-1) yields the voltage equation in the abcde system

$$V_s = R_s I_s + L_{ss} \frac{dI_s}{dt} + \omega_{rm} \frac{dL_{ss}}{d\theta_{rm}} I_s \quad (4-6)$$

### 5. Transformation of the Machine Voltage Equations to the Synchronous Reference Frame

The set of equations previously developed are sufficiently detailed to describe both the transient and steady state behavior of a five phase synchronous reluctance machine. However, these equations are rather complex due to the degree of coupling between windings. Also the mutual inductances are a function of the rotor position. It is desirable to represent the machine with a simpler set of equations without sacrificing any generality.

When space harmonics are ignored, there are well-known transformations that can bring about simplification, especially for three phase systems. However, when the space harmonics are included and the system has more than three phases the task is rather formidable. Fortunately for the five phase synchronous reluctance machine under study, the effect of third space harmonic plays a significant role. Therefore, the necessary transformation used to simplify the system is as follows

$$T(\theta) = \frac{2}{5} \begin{pmatrix} \cos \theta & \cos(\theta - \frac{2\pi}{5}) & \cos(\theta - \frac{4\pi}{5}) & \cos(\theta + \frac{4\pi}{5}) & \cos(\theta + \frac{2\pi}{5}) \\ \sin \theta & \sin(\theta - \frac{2\pi}{5}) & \sin(\theta - \frac{4\pi}{5}) & \sin(\theta + \frac{4\pi}{5}) & \sin(\theta + \frac{2\pi}{5}) \\ \cos 3\theta & \cos 3(\theta - \frac{2\pi}{5}) & \cos 3(\theta - \frac{4\pi}{5}) & \cos 3(\theta + \frac{4\pi}{5}) & \cos 3(\theta + \frac{2\pi}{5}) \\ \sin 3\theta & \sin 3(\theta - \frac{2\pi}{5}) & \sin 3(\theta - \frac{4\pi}{5}) & \sin 3(\theta + \frac{4\pi}{5}) & \sin 3(\theta + \frac{2\pi}{5}) \\ \frac{1}{\sqrt{2}} & \frac{1}{\sqrt{2}} & \frac{1}{\sqrt{2}} & \frac{1}{\sqrt{2}} & \frac{1}{\sqrt{2}} \end{pmatrix} \quad (5-1)$$

This transformation has the following pseudo orthogonal property

$$T(\theta)^{-1} = \frac{5}{2} T(\theta) \quad (5-2)$$

which explicitly is given by

$$T(\theta)^{-1} = \begin{pmatrix} \cos \theta & \sin \theta & \cos 3\theta & \sin 3\theta & \frac{1}{\sqrt{2}} \\ \cos(\theta - \frac{2\pi}{5}) & \sin(\theta - \frac{2\pi}{5}) & \cos 3(\theta - \frac{2\pi}{5}) & \sin 3(\theta - \frac{2\pi}{5}) & \frac{1}{\sqrt{2}} \\ \cos(\theta - \frac{4\pi}{5}) & \sin(\theta - \frac{4\pi}{5}) & \cos 3(\theta - \frac{4\pi}{5}) & \sin 3(\theta - \frac{4\pi}{5}) & \frac{1}{\sqrt{2}} \\ \cos(\theta + \frac{4\pi}{5}) & \sin(\theta + \frac{4\pi}{5}) & \cos 3(\theta + \frac{4\pi}{5}) & \sin 3(\theta + \frac{4\pi}{5}) & \frac{1}{\sqrt{2}} \\ \cos(\theta + \frac{2\pi}{5}) & \sin(\theta + \frac{2\pi}{5}) & \cos 3(\theta + \frac{2\pi}{5}) & \sin 3(\theta + \frac{2\pi}{5}) & \frac{1}{\sqrt{2}} \end{pmatrix} \quad (5-3)$$

Also, it can readily be shown that

$$T(\theta) \frac{dT(\theta)^{-1}}{dt} = \omega \begin{pmatrix} 0 & 1 & 0 & 0 & 0 \\ -1 & 0 & 0 & 0 & 0 \\ 0 & 0 & 0 & 3 & 0 \\ 0 & 0 & -3 & 0 & 0 \\ 0 & 0 & 0 & 0 & 0 \end{pmatrix} = \omega \times \quad (5-4)$$

Similarly

$$\frac{dT(\theta)}{dt} T(\theta)^{-1} = \omega \begin{pmatrix} 0 & -1 & 0 & 0 & 0 \\ 1 & 0 & 0 & 0 & 0 \\ 0 & 0 & 0 & -3 & 0 \\ 0 & 0 & 3 & 0 & 0 \\ 0 & 0 & 0 & 0 & 0 \end{pmatrix} = -\omega \times \quad (5-5)$$

Setting  $\theta=0$  results in the transformation to the stationary reference frame. Specifically,

$$T(0) = \frac{2}{5} \begin{pmatrix} 1 & \sqrt{\frac{3-\sqrt{5}}{8}} & -\sqrt{\frac{3+\sqrt{5}}{8}} & -\sqrt{\frac{3+\sqrt{5}}{8}} & \sqrt{\frac{3-\sqrt{5}}{8}} \\ 0 & -\sqrt{\frac{5+\sqrt{5}}{8}} & -\sqrt{\frac{5-\sqrt{5}}{8}} & \sqrt{\frac{5-\sqrt{5}}{8}} & \sqrt{\frac{5+\sqrt{5}}{8}} \\ 1 & -\sqrt{\frac{3+\sqrt{5}}{8}} & \sqrt{\frac{3-\sqrt{5}}{8}} & \sqrt{\frac{3-\sqrt{5}}{8}} & -\sqrt{\frac{3+\sqrt{5}}{8}} \\ 0 & \sqrt{\frac{5-\sqrt{5}}{8}} & -\sqrt{\frac{5+\sqrt{5}}{8}} & \sqrt{\frac{5+\sqrt{5}}{8}} & -\sqrt{\frac{5-\sqrt{5}}{8}} \\ \frac{1}{\sqrt{2}} & \frac{1}{\sqrt{2}} & \frac{1}{\sqrt{2}} & \frac{1}{\sqrt{2}} & \frac{1}{\sqrt{2}} \end{pmatrix} \quad (5-6)$$

Multiplying equation (2-1) by the necessary transformation given by equation (5-1) in order to transform the voltage equations into the synchronous rotating reference frame yields

$$T(\theta) V_s = R_s T(\theta) I_s + T(\theta) \frac{d\Lambda_s}{dt} \quad (5-7)$$

The second term of the right hand side in the above equation can be written using the chain rule again as

$$T(\theta) \frac{d\Lambda_s}{dt} = \frac{d}{dt} [T(\theta) \Lambda_s] - \frac{dT(\theta)}{dt} T(\theta)^{-1} T(\theta) \Lambda_s \quad (5-8)$$

Upon multiplying the stator flux linkages by the transformation yields the stator flux linkages in the dq system, given by

$$\mathbf{T}(\theta)\Lambda_s = \mathbf{T}(\theta)\mathbf{L}_{dqs}\mathbf{T}(\theta)^{-1}\mathbf{T}(\theta)\mathbf{I}_s = \mathbf{L}(\theta)_{dqs}\mathbf{I}_{dqs} = \Lambda_{dqs} \quad (5-9)$$

where  $\mathbf{L}_{dqs}(\theta)$  is the inductance matrix in the dqz system and can be written as

$$\mathbf{L}_{dqs} = \begin{pmatrix} L_{1s}+L_{md1} & 0 & L_{m13} & 0 & 0 \\ 0 & L_{1s}+L_{mq1} & 0 & L_{m13} & 0 \\ L_{m13} & 0 & L_{1s}+L_{md3} & 0 & 0 \\ 0 & L_{m13} & 0 & L_{1s}+L_{mq3} & 0 \\ 0 & 0 & 0 & 0 & L_{1s} \end{pmatrix} \quad (5-10)$$

where  $L_{1s}$  represents that portion of the leakage inductance which is not associated with flux in the air gap (slot and end winding leakage).

Since this component of leakage inductance is identical for all five phases, it passes unchanged under the dq transformation in much the same manner as the stator resistance. Using the method presented in the previous chapter, the mutual inductances are given by

$$L_{md1} = \frac{5}{2} K\pi \left[ \frac{421}{405} a - \frac{1}{2} b \right] \quad (5-11)$$

$$L_{mq1} = \frac{5}{2} K\pi \left[ \frac{421}{405} a + \frac{1}{2} b \right]$$

$$L_{md3} = \frac{5}{2} K\pi \left[ \frac{1}{9} a + \frac{1}{54} b \right]$$

$$L_{mq3} = \frac{5}{2} K\pi \left[ \frac{1}{9} a - \frac{1}{54} b \right]$$

$$L_{m13} = \frac{5}{2} K\pi \left[ \frac{1}{6} b \right]$$

It is important to notice that the transformation presented by (5-1) resulted successfully in a matrix inductance in the synchronous reference frame which is no longer a function of the rotor position.

Using equations (5-8,9) in (5-7) yields

$$\mathbf{V}_{dqs} = \mathbf{R}_s \mathbf{I}_{dqs} + \frac{d\Lambda_{dqs}}{dt} + \omega \mathbf{x} \Lambda_{dqs} \quad (5-12)$$

which can be written in vector form as

$$\begin{pmatrix} v_{ds1} \\ v_{qs1} \\ v_{ds3} \\ v_{qs3} \\ v_{ns} \end{pmatrix} = \mathbf{r}_s \begin{pmatrix} i_{ds1} \\ i_{qs1} \\ i_{ds3} \\ i_{qs3} \\ i_{ns} \end{pmatrix} + \frac{d}{dt} \begin{pmatrix} \lambda_{ds1} \\ \lambda_{qs1} \\ \lambda_{ds3} \\ \lambda_{qs3} \\ \lambda_{ns} \end{pmatrix} + \omega \begin{pmatrix} 0 & 1 & 0 & 0 & 0 \\ -1 & 0 & 0 & 0 & 0 \\ 0 & 0 & 0 & 3 & 0 \\ 0 & 0 & -3 & 0 & 0 \\ 0 & 0 & 0 & 0 & 0 \end{pmatrix} \begin{pmatrix} \lambda_{ds1} \\ \lambda_{qs1} \\ \lambda_{ds3} \\ \lambda_{qs3} \\ \lambda_{ns} \end{pmatrix} \quad (5-13)$$

In summary, the voltage equations in terms of flux linkages can therefore be written as

$$v_{ds1} = r_s i_{ds1} + \omega \lambda_{qs1} + \frac{d\lambda_{ds1}}{dt} \quad (5-14)$$

$$v_{qs1} = r_s i_{qs1} - \omega \lambda_{ds1} + \frac{d\lambda_{qs1}}{dt} \quad (5-15)$$

$$v_{ds3} = r_s i_{ds3} + 3\omega \lambda_{qs3} + \frac{d\lambda_{ds3}}{dt} \quad (5-16)$$

$$v_{qs3} = r_s i_{qs3} - 3\omega \lambda_{ds3} + \frac{d\lambda_{qs3}}{dt} \quad (5-17)$$

$$v_{ns} = r_s i_{ns} + \frac{d\lambda_{ns}}{dt} \quad (5-18)$$

In a five phase balanced system without a neutral connection, the zero sequence current (n-axis current) does not exist resulting only in four equations. The flux linkages are explicitly presented by

$$\lambda_{ds1} = [L_{1s} + L_{md1}] i_{ds1} + L_{m13} i_{ds3} \quad (5-19)$$

$$\lambda_{qs1} = [L_{1s} + L_{mq1}] i_{qs1} + L_{m13} i_{qs3} \quad (5-20)$$

$$\lambda_{ds3} = [L_{1s} + L_{md3}] i_{ds3} + L_{m13} i_{ds1} \quad (5-21)$$

$$\lambda_{qs3} = [L_{1s} + L_{mq3}] i_{qs3} + L_{m13} i_{qs1} \quad (5-22)$$

$$\lambda_{ns} = I_{1s} i_{hs} \quad (5-23)$$

It is clear that if no third harmonic of current is applied,  $\lambda_{ds3}$  and  $\lambda_{qs3}$  still do exist which is due to the choice of  $90^\circ$  pole arc for the rotor.

Using equations (5-14) to (5-17), the equivalent circuit of the five phase synchronous reluctance machine in the synchronous dq-frame is given in Figure (5-1).

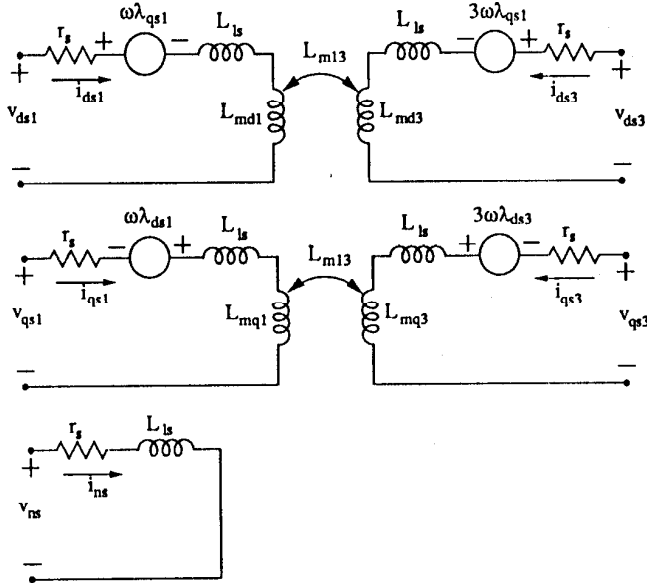

Figure 5-1 The equivalent circuit of the five phase synchronous reluctance machine in the synchronous reference frame.

The mechanical equation of motion depends upon the characteristics of the load which may differ widely from one application to the next. We will assume here, for simplicity, that the torque which opposes that produced by the machine consists only of an inertial torque and an external load torque which are known explicitly. In this case the mechanical equation of motion is simply

$$J \frac{d^2 \theta_{rm}}{dt^2} + T_L = T_e \quad (6-1)$$

where  $\theta_{rm}$  is the angular displacement of the rotor,  $T_L$  is the load torque, and  $T_e$  is the electromagnetic torque produced by the machine.

The electrical torque can be found from the magnetic coenergy  $W_{co}$

$$T_e = \left( \frac{\partial W_{co}}{\partial \theta_{rm}} \right)_{(I_s \text{ constant})} \quad (6-2)$$

In a linear magnetic system the coenergy is equal to the stored magnetic energy

$$W_{co} = \frac{1}{2} I_s^t L_{ss} I_s \quad (6-3)$$

Therefore the electromagnetic torque will be

$$T_e = \frac{1}{2} I_s^t \frac{\partial L_{sr}}{\partial \theta_{rm}} I_r \quad (6-4)$$

Thus far we have assumed, for simplicity, that the machine has only two poles. In general, let  $P$  denote the number of motor poles. It is clear that any inductance which is a function of angular displacement undergoes  $P/2$  complete cycles as  $\theta_{rm}$  varies from 0 to  $2\pi$ . That is

$$\theta_r = \frac{P}{2} \theta_{rm} \quad (6-5)$$

The angle  $\theta_r$  is called the rotor displacement in electrical radians. In terms of  $\theta_r$ , the torque is clearly

$$T_e = \frac{P}{4} I_s^t \frac{\partial L_{ss}}{\partial \theta_r} I_s \quad (6-6)$$

Using the transformation in the following equation results in

$$T_e = \frac{P}{4} [T(\theta) I_s]^t \frac{5}{2} T(\theta) \frac{\partial L_{ss}}{\partial \theta_r} T^{-1}(\theta) [T(\theta) I_s] \quad (6-7)$$

Since

$$T(\theta) \frac{dL_s(\theta)}{dt} T^{-1}(\theta) = (L_{mq1} - L_{md1}) \begin{pmatrix} 0 & 1 & 0 & -\frac{1}{3} & 0 \\ 1 & 0 & \frac{1}{3} & 0 & 0 \\ 0 & \frac{1}{3} & 0 & -\frac{1}{9} & 0 \\ -\frac{1}{3} & 0 & -\frac{1}{9} & 0 & 0 \\ 0 & 0 & 0 & 0 & 0 \end{pmatrix} \quad (6-8)$$

the electromagnetic torque for a five phase current regulated synchronous reluctance motor is given by the following algebraic equation.

$$T_e = -\frac{P}{2} \frac{5}{2} (L_{md1} - L_{mq1}) i_{e1} i_{e3} - 2 L_{m13} i_{e2} i_{e4} +$$

$$L_{m13} i_{e3} + 3 [L_{md3} + L_{mq3}] i_{e3} i_{e3} \quad (6-9)$$

This equation clearly represent the dependence of the electromagnetic torque on the fundamental and third harmonic of d and q axes currents. For our choice of rotor structure with no flux barrier, the effect of third harmonic magnetizing inductances are shown with constant terms in equation (6-9). In cases where the machine is subjected to only fundamental current, then the resultant electromagnetic torque equation will be

$$T_e = -\frac{P}{2} \frac{5}{2} [L_{md1} - L_{mq1}] i_{d1} i_{q1} \quad (6-10)$$

which is the familiar equation given for the synchronous reluctance machine operated from a sinusoidal supply modified for five phases. Another result of equation (6-9) is the fact that if the third harmonic of current does not exist, there will not be any associated third harmonic component of torque. However, a third harmonic of inductance will still have an influence on the terminal voltage and stator current.

### 7. Digital Computer Simulation Results

In order to demonstrate the importance of this new model, a four pole synchronous reluctance machine with five phases was simulated. In this study, the machine studied was assumed to have 24 stator slots. The rotor was considered to have four poles with a 90° pole arc. It was assumed that motor shaft is rotating at constant speed. Three different cases have been studied. Case I is based on the method presented in [2]. Case II assumes a sinusoidal variation of the inductances with respect to rotor position. Case III uses the d-q method including the third harmonic of the winding functions presented already in this paper. Figure 7-1 illustrates the total flux linking phase a assuming that machine is excited with fundamental current only at full load. The result is the same as that predicted from the usual three phase d-q model except for that the torque is appropriately increased due to the use of five rather than three phases. Figure 7-2 shows the corresponding electromagnetic torque showing the same average torque for all cases.

Shown in Figure 7-3 are the stator flux linkages when the machine is excited with a combined fundamental and 33% third harmonic of current whereby the rms current is maintained as the same value as in Figure 7-1. Since the rms current is the same in Figure 7-1 and 7-3 the total copper losses are therefore equal. Figure 7-4 illustrates the electromagnetic torque for this situation. Notice the error in the output torque which exists when only sinusoidal variation of the inductances are considered. However, since the machine is excited with the combined fundamental and third harmonic of the current the fundamental torque is reduced because of addition of third harmonic in the current. On the contrary if the effect of third harmonic in the inductances is considered as shown in Figure 7-4 there is at least 10% improvement in the torque production.

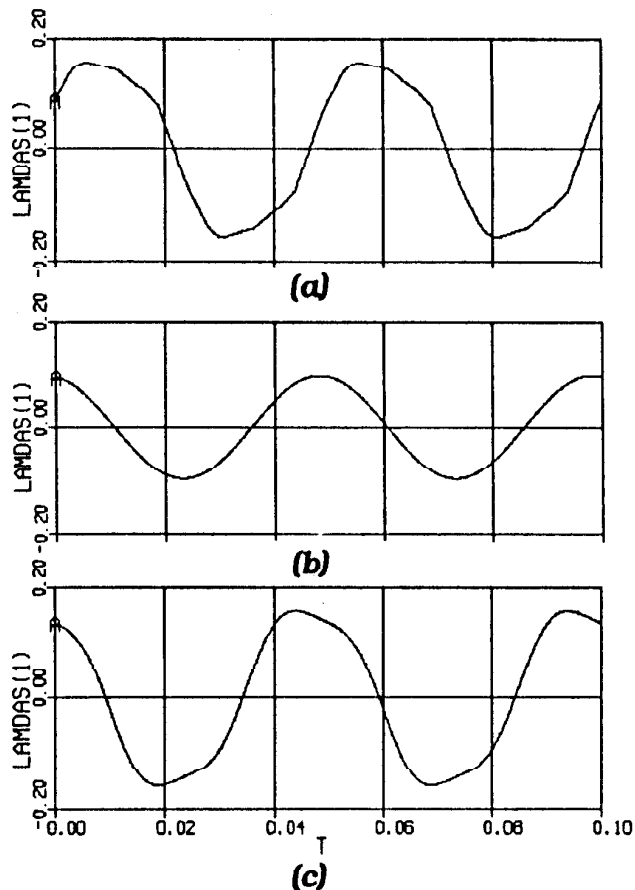

Figure 7-1 Stator Flux Linkages of Phase a at Full load under only Fundamental Current Excitation, a) Case I, b) Case II, c) Case III.

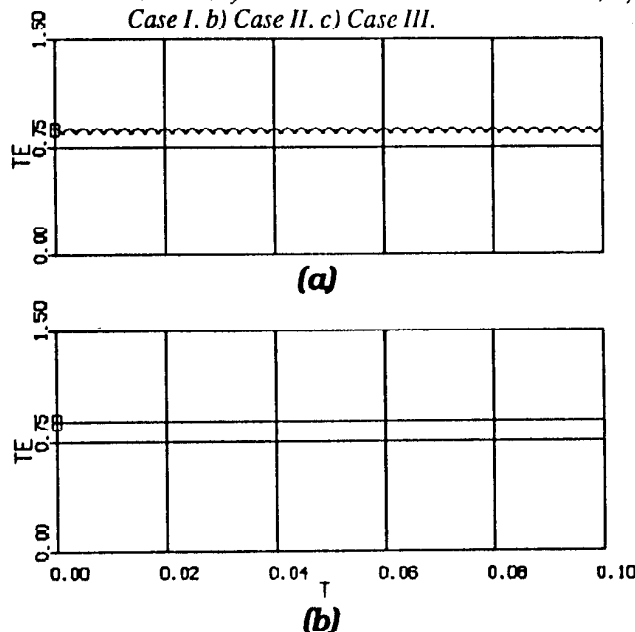

Figure 7-2 Electromagnetic Torque Developed Under Conditions of Figure 7-1, a) Case I, b) Case II, c) Case III. (continued)



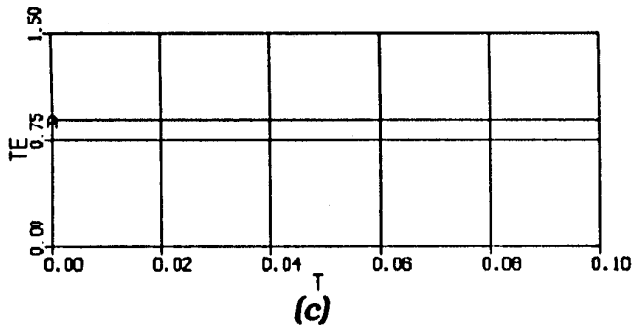

Figure 7-2 Electromagnetic Torque Developed Under Conditions of Figure 7-1, a) Case I, b) Case II, c) Case III. (continued)

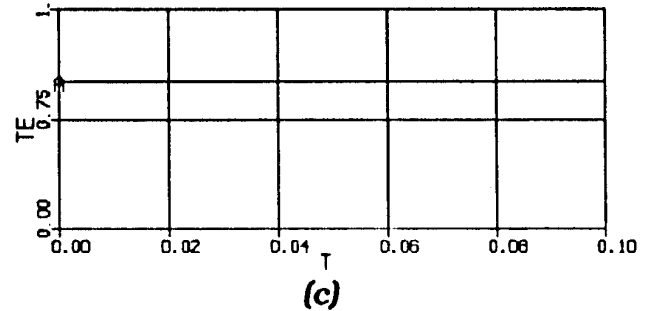
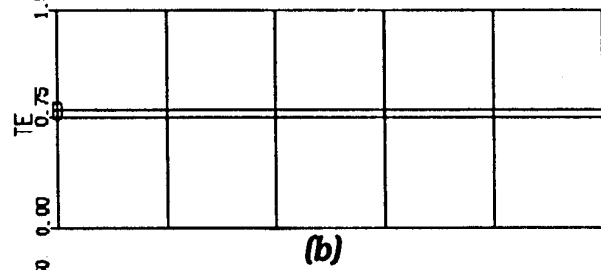
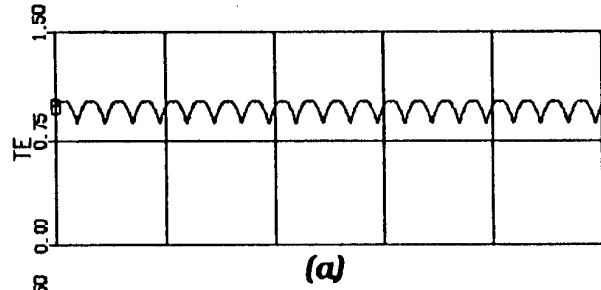

Figure 7-4 Electromagnetic Torque Developed Under Conditions of Figure 7-3, a) Case I, b) Case II, c) Case III.

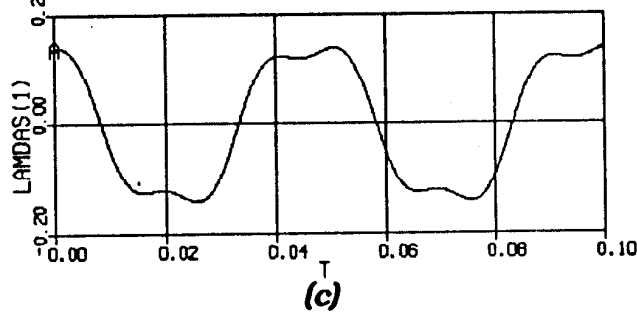
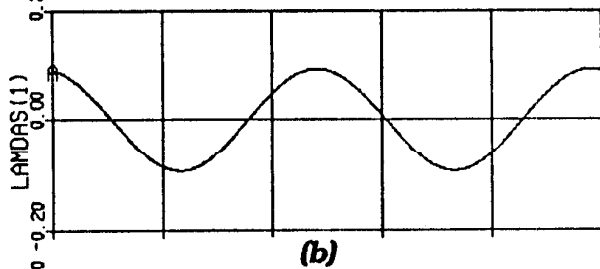
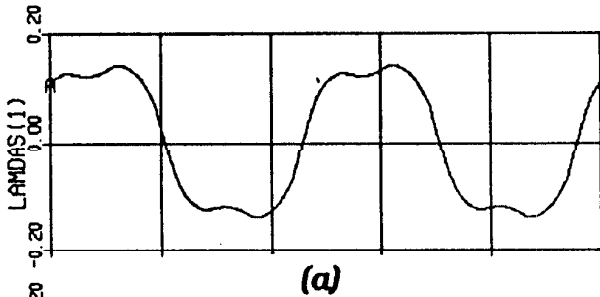

Figure 7-3 Stator Flux Linkages of Phase a at Full load under Combined Fundamental and Third Harmonic of Current Excitation, a) Case I, b) Case II, c) Case III.

## 8. Experimental Results

In order to verify the new model that has been developed a five phase synchronous reluctance motor designed and fabricated in a standard frame size rated at 7.5 hp, four pole, 60Hz, 460 V, three phase for an induction motor. However, the stator of the five phase machine has 40 slots rather than 36 as was the case for the original stator for the induction machine. The machine is wound with full pitch single layer coils and has four poles which results in 2 slots per pole per phase. The salient pole rotor was milled from the corresponding three phase squirrel cage induction motor. Half of the pole pitch area for each pole was milled away to resemble the 90 electrical degrees pole arc achieved in the previous analysis.

The machine was excited with only half of the windings energized, meaning one slot per pole per phase. In this case the MMF produced by exciting a coil at one instant of time resemble a rectangular waveform. Therefore, the assumption of rectangular waveforms for the winding functions are more realistic. However, energization of the entire machine results in a stepwise MMF for each coil which requires a certain

linking one stator coil after integration of the voltage induced in a search coil parallel to that phase. The high frequency noise is due to the switching. The machine is running at no load under a combined excitation of fundamental and 33% third harmonic. For the sake of comparison, the digital computer result using d-q modeling is given in Figure 8-2. The similarity between the experimental result and the simulation using the d-q model is obvious.

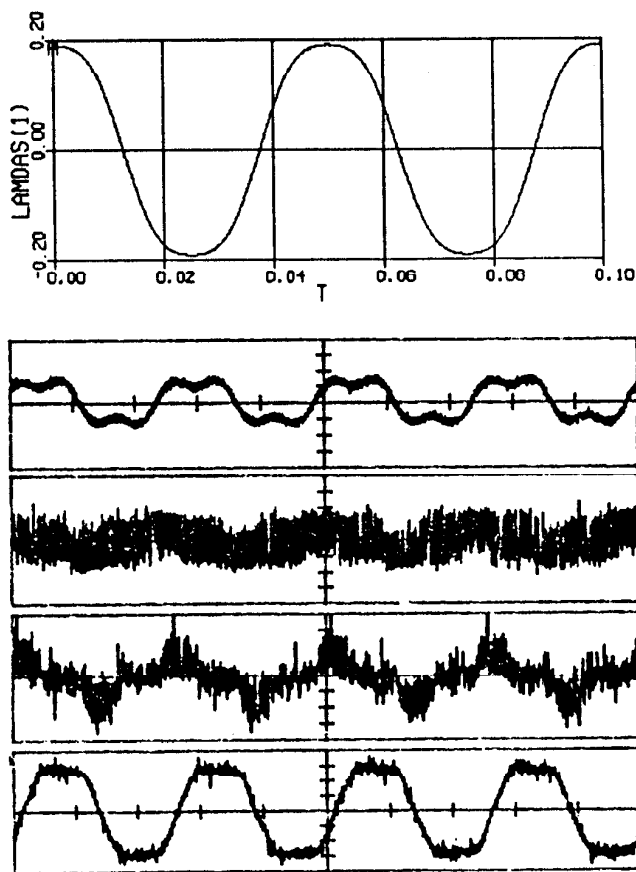

Figure 8-1 Comparison of Calculated and Measured Stator Flux Linkages at no load. Top Trace, Digital Computer Result in volts.sec. Bottom Trace, Test Results. From top to bottom: Stator current (5 A/div.), Phase voltage (50 V/div.), Search Coil Voltage (200 mV/div.), Stator Phase Flux Linkages (69 mV.sec./div. and 20 msec./div).

## 9. Conclusion

In this paper a detailed analysis of the development of the d-q equations for a five phase synchronous reluctance machines including the third harmonic of the air-gap MMF was presented. An equivalent circuit based on these equations was developed. A digital computer simulation was used to confirm the model, and as a means of comparison between the d-q model and the equations in the natural system (abc

variables). The computer results were compared to the experimental traces obtained from a specially constructed machine. Agreement between measured and calculated waveforms was demonstrated.

## Acknowledgement

The authors wish to acknowledge the financial support provided by the Wisconsin Electric Machines and Power Electronics Consortium (WEMPEC) for funds and equipment.

## References

- [1] T. A. Lipo, "A d-q Model for Six Phase Induction Machines", International Conference on Electrical Machines, Sept. 15-17, 1980, Athens, Greece, pp. 860-867.
- [2] H. A. Toliyat, L. Xu and T. A. Lipo, "A Five Phase Reluctance Motor With High Specific Torque", Conf. Rec. IEEE-IAS Annual Meeting, 1990.
- [3] H. A. Toliyat, T.A. Lipo, J.C. White, "Analysis of a Concentrated Winding Induction Machine for Adjustable Speed Drive Applications-Part I (Motor Analysis)", IEEE-PES Winter Meeting, February 3-7, 1991.
- [4] H. A. Toliyat, T.A. Lipo, J.C. White, "Analysis of a Concentrated Winding Induction Machine for Adjustable Speed Drive Applications-Part II (Motor Design and Performance)", IEEE-PES Winter Meeting, February 3-7, 1991.
- [5] H. A. Toliyat, "Analysis of Concentrated Winding Induction and Reluctance Motors for Adjustable Speed Drive Applications", Ph.D. Thesis, University of Wisconsin-Madison, May 1991.
- [6] T. A. Lipo, "Theory and Control of Synchronous Machines." Class Notes, University of Wisconsin-Madison, 1987.