

Wisconsin Electric Machines and Power Electronics Consortium

RESEARCH REPORT
93-2

Analysis of Voltage Controlled Induction Motors
Using Quasi-Rotating Reference Frame

N.H. Kutkut, H.M. Cherradi, T.A. Lipo
Dept. of Electrical and Computer Engineering
University of Wisconsin-Madison
1415 Johnson Drive
Madison, WI 53706

WEMPEC

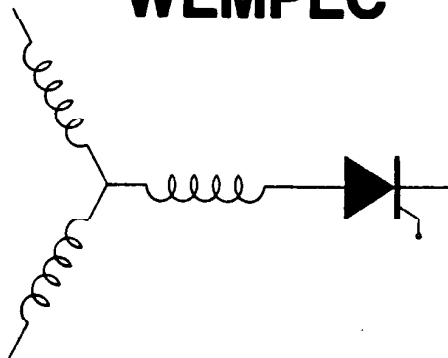

Department of Electrical and Computer Engineering
1415 Johnson Drive
Madison, Wisconsin 53706
© May 1993 Confidential

ANALYSIS OF VOLTAGE CONTROLLED INDUCTION MOTORS USING QUASI-ROTATING REFERENCE FRAME

Nasser H. Kutkut

Hassan M. Cherradi

Thomas A. Lipo

Department of Electrical and Computer Engineering
University of Wisconsin - Madison
1415 Johnson Drive, Madison, WI 53706
Tel : (608) 262-0287, Fax : (608) 262-1267

Abstract- The speed control of induction machines using back-to-back thyristors in each phase of the machine is a simple scheme. Yet, even the steady state analysis of this system becomes complex since voltage adjustment is obtained by sequentially open-circuiting the stator phases. In this paper, a new analytical approach for predicting the steady state performance of this system is presented. By using a dq model and properly choosing the dq frame, the steady state solution can be obtained with minimal complexity. In particular, by utilizing a special "quasi-synchronously" rotating reference frame, only three modes of the system need be defined rather than seven, and the steady state solution is simply a combination of these modes. Simulation results are included to show the validity of this scheme. It is shown that the method can be extended to model transient behavior with the proper precautions.

1. INTRODUCTION

Many schemes have been developed in order to control the speed of the induction motor using thyristors. The most straight forward approach is the use of back to back thyristors in the supply line of an induction machine to adjust the effective voltage applied to the stator terminals. Since the output torque is a function of the square of the air gap emf, variation in the terminal voltage results in an inexpensive and reliable means of adjusting the motor speed. In many cases, stator voltage control is not practical owing to the resulting poor efficiency of this scheme. Hence, the method is normally applied in low and medium power applications wherein the load torque varies as the square of the motor speed. Such applications are typically fan pump loads in the 5 - 150 hp range.

In spite of the simplicity of the scheme, even the steady state analysis is rather complex since voltage adjustment is obtained by sequentially open-circuiting the stator phases. Some approximate analyses have been reported in the literature [1] for a delta connected primary. A more exact analysis was done by Lipo [2], where state variables' techniques were used to derive an expression for the average torque using the first harmonic of the stator current. Implicit solutions by analog and digital simulation techniques were also obtained [3]. However, such an approach does not lend itself to system design aspects which generally require a repeated number of steady state solutions.

In this paper, a new approach is proposed to analyze such systems. By using the usual induction motor dq model and by properly choosing a reference frame which rotates with the switching of the thyristors, the steady state solution of the system can be obtained with a minimum effort.

2. BASIC CONSIDERATIONS

The system investigated, shown in Fig. 1, consists of a three-phase power source, three pairs of back-to-back SCRs in series with the phases of a wye connected machine. The gating signals of the thyristors are typically derived from the zero crossings of the voltage or current of the three phase power source. Stator voltage

control is generally achieved by alternately open-circuiting the three stator currents at zero instant currents.

In this paper, the following assumptions are made:

- a- The power source is a set of balanced three phase sinusoidal voltages.
- b- The thyristors have identical characteristics and are symmetrically triggered. They are considered as an infinite impedance in the blocking mode and a zero impedance in the conduction mode.
- c- The induction machine is ideal and saturation of the machine is neglected.

3. SYMMETRY CONSIDERATIONS

Due to the symmetry of the applied source voltage, and the symmetry of the resulting currents, a considerable reduction of the analysis is possible. A typical steady-state response of the system of Fig. 1 is shown in Fig. 2, which serves to set forth the notation used and to illustrate the symmetry of the solution.

In the steady-state, an induction machine operates as an inductive load where a phase current lags its respective voltage by a phase angle ϕ . The delay from the instant of zero phase voltage to the conduction of the succeeding thyristor in that phase is termed the delay angle α .

The delay from the instant of the phase current reaches zero to the firing of the succeeding thyristor in that phase is referred to as the current hold-off angle γ . These angles are illustrated in Fig. 2.

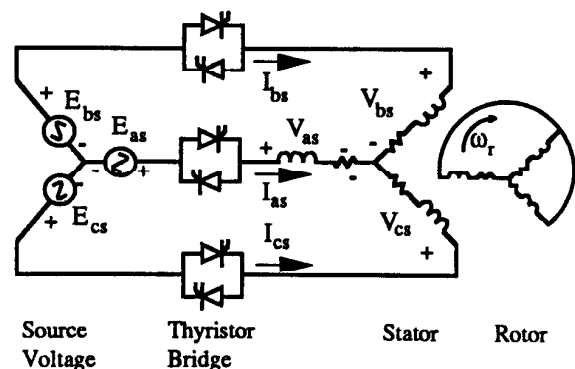

Fig. 1: System Investigated

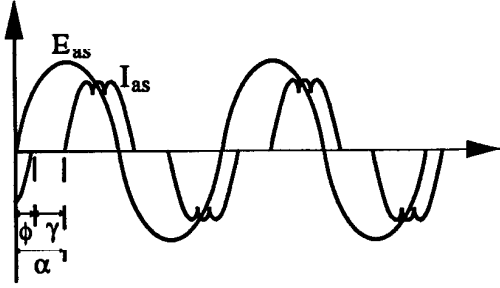

Fig. 2: Typical Steady-State Response of the System

Since the thyristors are assumed to be identical and are fired symmetrically, the current hold-off angle γ , the phase angle ϕ and the delay angle α associated with the turn off of each thyristor are all identical. In fact, it has been shown by Lipo that the analysis carried out for a single $\pi/3$ interval is sufficient to uniquely define all other variables over an entire period. Five possible modes of the system were identified by Lipo [2] where the currents are either all non-zero, only one current is zero or all currents are zero. The state variable technique was used to solve for the system response.

4. dq ANALYSIS

A considerable reduction in the circuit modes of the system can be obtained by using the dq analysis. The dq equations of the system in a stationary reference frame written in terms of the stator and rotor dq currents are listed below:

$$\frac{d}{dt} i_{qs} = \frac{1}{\sigma L_s} (v_{qs} - r_s i_{qs} - \omega_r \frac{L_m^2}{L_r} i_{ds} - \omega_r L_m i_{dr}' + \frac{L_m}{T_r} i_{qr}') \quad (1)$$

$$\frac{d}{dt} i_{ds} = \frac{1}{\sigma L_s} (v_{ds} - r_s i_{ds} + \omega_r \frac{L_m^2}{L_r} i_{qs} + \omega_r L_m i_{qr}' + \frac{L_m}{T_r} i_{dr}') \quad (2)$$

$$\frac{d}{dt} i_{qr}' = \frac{L_m}{\sigma L_s L_r} (-v_{qs} + r_s i_{qs} + \omega_r L_s i_{ds} - \frac{L_s}{L_m} r_r i_{dr}' - \omega_r \frac{L_s L_r}{L_m} i_{dr}') \quad (3)$$

$$\frac{d}{dt} i_{dr}' = \frac{L_m}{\sigma L_s L_r} (-v_{ds} + r_s i_{ds} - \omega_r L_s i_{qs} - \frac{L_s}{L_m} r_r i_{dr}' - \omega_r \frac{L_s L_r}{L_m} i_{qr}') \quad (4)$$

$$T_e = \frac{3P}{4} X_m (i_{qs} i_{dr}' - i_{ds} i_{qr}') \quad (5)$$

$$\frac{d}{dt} \omega_r = \frac{3P}{4J} (T_e - T_l) - \frac{B}{J} \omega_r \quad (6)$$

The voltages v_{qs} and v_{ds} are computed via the transformation,

$$v_{qs} = \frac{2}{3} [v_{as} \cos(\theta_{rf}) + v_{bs} \cos(\theta_{rf} - \frac{2\pi}{3}) + v_{cs} \cos(\theta_{rf} + \frac{2\pi}{3})] \quad (7)$$

$$v_{ds} = \frac{2}{3} [v_{as} \sin(\theta_{rf}) + v_{bs} \sin(\theta_{rf} - \frac{2\pi}{3}) + v_{cs} \sin(\theta_{rf} + \frac{2\pi}{3})] \quad (8)$$

where θ_{rf} is the angle of the stationary reference frame. Normally, in a stationary reference frame fixed in the stator, the angle θ_{rf} is zero. Upon solving for the system variables in the dq domain, the stator and rotor currents can be computed using the transformation,

$$i_{as} = i_{qs} \cos(\theta_{rf}) + i_{ds} \sin(\theta_{rf}) \quad (9)$$

$$i_{bs} = i_{qs} \cos(\theta_{rf} - \frac{2\pi}{3}) + i_{ds} \sin(\theta_{rf} - \frac{2\pi}{3}) \quad (10)$$

$$i_{cs} = i_{qs} \cos(\theta_{rf} + \frac{2\pi}{3}) + i_{ds} \sin(\theta_{rf} + \frac{2\pi}{3}) \quad (11)$$

5. QUASI-ROTATING REFERENCE FRAME

In the preceding section, the system equations were written in a dq stationary reference frame. The angle θ_{rf} was the angle of the stationary reference frame. As mentioned earlier, θ_{rf} is zero for a stationary reference frame fixed in the stator in which case the q-axis is lined up with phase a of the stator. In fact, if θ_{rf} is chosen to be any value other than zero, only the transformation will change, and by taking the inverse transformation correctly, the original system is recovered. On the other hand, if θ_{rf} is suddenly changed in a discrete manner at any point and the inverse transformation is performed correctly, the original system will not be affected. Thus the main innovation of this work is to discretely change the position of the dq axis as various switching events occur. The position of the reference frame axes θ_{rf} will be suddenly changed in discrete steps while continuously performing the corresponding inverse transformation to recover the system response. This new concept is referred to as a "Quasi-Rotating Reference Frame" (QRF).

In order to show the validity of the Quasi-Rotating Reference Frame concept, a 5 hp machine was simulated based on this. At the beginning, the reference frame was fixed in phase as of the machine and then shifted in space every $\pi/3$ time period by 60° degrees. The resulting ACSL simulation results are shown in Fig. 3.

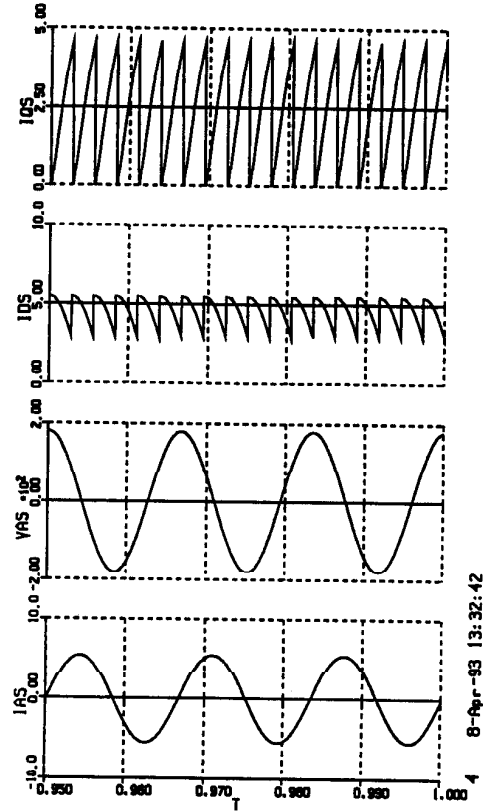

Fig. 3: Simulation Results for a 5 hp Machine Operating Under a No Load Condition.

6. CIRCUIT MODES

The overall system (the induction machine and the thyristor bridge) can be simplified by applying the QRF concept. The q-axis of the dq frame is switched so as to always be aligned with the machine phase where the current has just reached zero (where the corresponding thyristor will turn off). Hence, the q-axis current, i_{qs} , will always be zero for the period of the hold off angle, γ . After the time corresponding to the angle γ , the anti parallel thyristor of that phase will turn on and i_{qs} will no longer be zero. After this instant, the dq frame will be suddenly shifted by the angle $\pi/3$ when the current in the next phase reaches zero. At this instant the current i_{qs} will again be zero for the time period corresponding to γ and non zero afterwards. In the steady state, the dq frame must continually be stepped by $\pi/3$ radians in space for every 60 degrees in time. This concept is shown in Fig. 4..

By continually applying this technique, only three circuit modes are required to uniquely identify all possible operating modes of the system. These modes are defined as follows,

MODE I: Both i_{qs} and i_{ds} are non-zero.

In this case, the dq equations described earlier are used to solve for the system variables. This mode can exist only for $0 \leq \gamma \leq \pi/3$ where both i_{qs} and i_{ds} are non-zero for the period of $\pi/3 - \gamma$. The equivalent circuit for this mode is shown in Fig. 5.

MODE II: $i_{qs} = 0$ and i_{ds} is non-zero.

In this case, since i_{qs} is zero, the induced voltage v_{qs} is computed via,

$$v_{qs} = \omega_r \frac{L_m^2}{L_r} i_{ds} + \omega_r L_m i_{dr}' - \frac{L_m}{T_r} i_{qr}' \quad (12)$$

The rest of the system variables are computed via the dq equations described earlier. This mode can exist for $0 \leq \gamma \leq \pi/3$ and $\pi/3 \leq \gamma \leq 2\pi/3$. The equivalent circuit for this mode is shown in Fig. 6.

MODE III: Both i_{qs} and i_{ds} are zero.

In this case, since both i_{qs} and i_{ds} are zero, the induced voltages v_{qs} and v_{ds} are computed via,

$$v_{qs} = \omega_r L_m i_{dr}' - \frac{L_m}{T_r} i_{qr}' \quad (13)$$

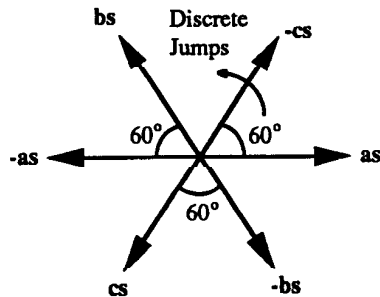

Fig. 4: Quasi-Rotating Reference Frame (Discrete Jumps by 60°)

while the currents i_{qr} and i_{dr} are computed via,

$$v_{ds} = -\omega_r L_m i_{qr}' - \frac{L_m}{T_r} i_{dr}' \quad (14)$$

$$\frac{d}{dt} i_{qr}' = -\frac{i_{qr}'}{T_r} + \omega_r i_{dr}' \quad (15)$$

$$\frac{d}{dt} i_{dr}' = -\frac{i_{dr}'}{T_r} - \omega_r i_{qr}' \quad (16)$$

This mode can exist for $\pi/3 \leq \gamma \leq 2\pi/3$ and $2\pi/3 \leq \gamma \leq \pi$. The equivalent circuit for this mode is shown in Fig. 7.

For the case where $2\pi/3 \leq \gamma \leq \pi$ only Mode III can exist, where both i_{qr} and i_{dr} are zero.

For a given angle γ , the steady state solution is simply a combination of these modes. Using this approach provides a more insightful way of analyzing the system.

7. SIMULATION RESULTS

In this section, ACSL simulation results are presented to show the validity of the proposed scheme. A 5 hp machine with 15 Nm load torque and with $\gamma = 30^\circ$ was simulated using the QRF concept. For this case, and since $0 \leq \gamma \leq \pi/3$, only circuit modes I & II can exist, where either both i_{qs} and i_{ds} are non-zero or where i_{qs} is zero and i_{ds} is non-zero. The steady state wave forms are shown in Fig. 8. Note in Fig. 8 that the circuit modes can be clearly seen from the i_{qs} wave form.

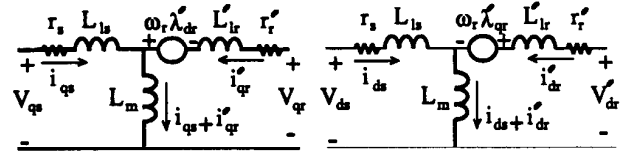

Fig. 5: Equivalent Circuit for Mode I.

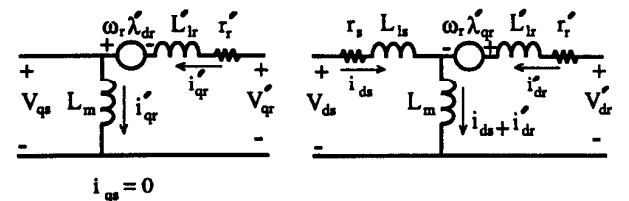

Fig. 6: Equivalent Circuit for Mode II.

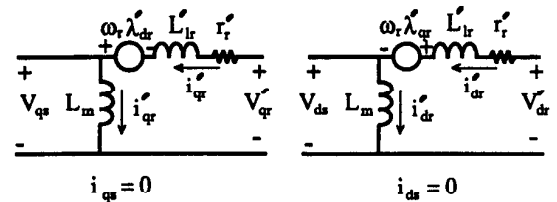
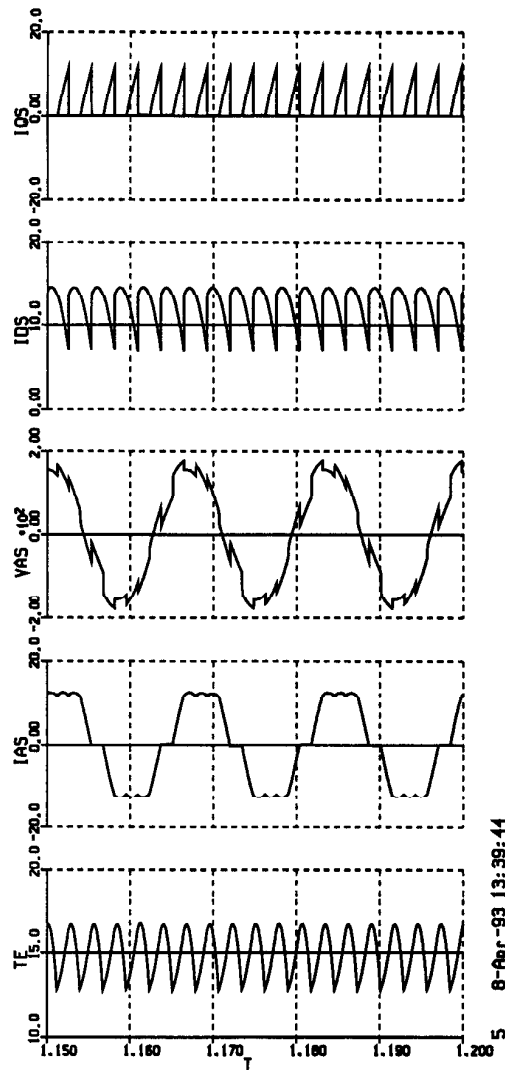

Fig. 7: Equivalent Circuit for Mode III.



- [3] P.C Krause, "A Constant Frequency Induction Motor Speed Control," Proc. National Electronics Conf., vol 20, pp. 361-365, 1964.
- [4] Xu, Longya, "Dynamic Model of an Integral-Cycle Controlled Single-Phase Induction Machine". IEEE Winter Power Meeting, February 1992.

Fig. 8: Simulation Results for a 5 hp Machine Operating Under 15 N.m Load with $\gamma = \pi/6$

8. CONCLUSION

This paper has presented a new approach to the analysis of the steady state operation of a voltage controlled induction motor drive. The analysis uses a special reference frame which is advanced or suddenly stepped every 60 electrical degrees so as to keep the q-axes aligned with the phase undergoing an open circuit. While the transient behavior of such a speed control system has not been the subject of this paper it should be noted that the approach introduced in this paper can be readily extended to the study of transient behavior.

REFERENCES

- [1] D.A. Paice, "Induction Motor Speed Control by Stator Voltage Control," IEEE TRANS. on PAS, vol. PAS 87, pp. 585-590, Feb. 1968.
- [2] T.A. Lipo, "The Analysis of Induction Motors With Voltage Control by Symmetrically Triggered Thyristors," IEEE TRANS. on PAS, vol. PAS-90, No. 2, pp. 515-525, March / April 1971.