

# Disturbance-Free Operation of a Multiphase Current-Regulated Motor Drive with an Opened Phase

Jen-Ren Fu and Thomas A. Lipo, *Fellow, IEEE*

**Abstract**—Although design of induction motor drives employing field oriented control has reached a relatively mature state, relatively little effort has been directed toward improving the reliability of these drives. In this paper, a new, improved induction motor control strategy is proposed incorporating a multiphase machine that allows for continuous, disturbance-free operation of the drive even with complete loss of one (or more) legs of the inverter or motor phase. A complete analysis of both an even phase and an odd phase machine utilizing this new control and circuit concept is included.

## I. INTRODUCTION

IN THE past several decades substantial progress has been made in the development of ac motor drives using both hard-switched dc link and resonant-link power conversion. These converters typically utilize high-speed switching devices such as fast recover bipolar junction transistors, insulated gate bipolar transistors (IGBT's) and GTO's. Control strategies, particularly field-oriented control strategies, have also greatly improved the performance of ac motor drives. These control strategies utilize almost exclusively pulse width modulated (PWM) switching strategies that exploit the low-switching-loss capability of these converters and seek to produce a precisely controlled current to the windings of the motor. In effect, the field-oriented controller serves to convert to dc/ac inverter from a voltage to a current source, thereby overcoming many of the inaccuracies involved in induction motor torque control.

While current regulation has greatly improved the torque response of ac drives, the use of this principle as a means of avoiding problems during system faults remains relatively unappreciated. One common type of fault is the loss of a transistor in one of the legs of the inverter, or alternatively, the loss of one of the phases of the motor. In this case, one of the motor phases is suddenly open circuited, essentially single phasing the motor, resulting in a loss of field orientation and in high double line frequency pulsating torques. A topology for a three-phase machine has recently been proposed to solve this problem

Paper IPCSD 94-24, approved by the Industrial Drives Committee of the IEEE Industry Applications Society for presentation at the 1993 IAS Annual Meeting. Manuscript released for publication April 21, 1994.

J.-R. Fu is with the Nuclear Engineering Department, Taiwan Power Company, Taipei, Taiwan.

T. A. Lipo is with the Department of Electrical and Computer Engineering, University of Wisconsin—Madison, Madison, WI 53706.  
IEEE Log Number 9404069.

[1]. By considering the drive circuit shown in Fig. 1, in the event that a transistor fails open in the inverter, a new current control strategy can be initiated by the converter that preserves the torque at its original value, or changes the torque to any desired value while eliminating the negative pulsating torque usually associated with operation with an open phase.

In the case of a three-phase machine, a neutral line connected between the motor neutral and the dc midpoint is required after one phase is open circuited so that the current in the remaining two phases can be individually controlled. In other words, a zero-sequence component is required in a three-phase machine to provide an undisturbed rotating MMF after one phase is open circuited. However, in a five-phase or a seven-phase machine, it is possible to take advantage of the additional degrees of freedom as a result of more phases. The current combination required to provide the same rotating MMF after one phase is open circuited is no longer unique. It can be shown that when one phase is open circuited, with appropriate control, the zero-sequence current is no longer a necessary component as in a three-phase machine. That is, it becomes possible to eliminate the use of a neutral line and still ensure that the machine be controlled so as to produce a smooth nonpulsating torque. Fig. 2 shows an example of an induction motor drive in which the machine has five, rather than three phases.

## II. ANALYSIS METHOD

The rotating MMF due to the currents in the winding of an induction motor, whatever the number of phases, can be developed by a two-winding system, if they are excited in an appropriate manner. By use of current-regulated pulse width modulation, the MMF is assumed to be sinusoidally distributed along the airgap, so that the combination of the direct-axis and quadrature-axis sinusoidal waves can represent this airgap wave. Neglect of the higher space harmonics is normally an accepted practice to simplify the equations.

If one phase of a multiphase machine is open circuited, the combination of phase currents required to generate an undisturbed rotating MMF is no longer unique. The most important consideration then is to establish an optimum set of currents that requires minimum current magnitudes (minimum  $I^2R$  loss). Whether a neutral line is

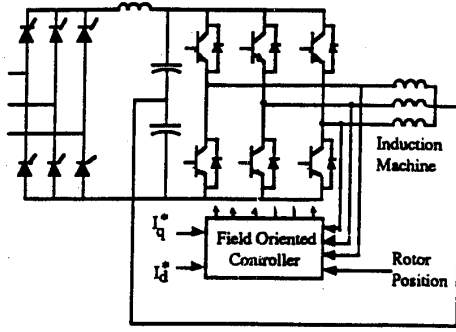

Fig. 1. Induction motor drive with machine neutral fed back to dc bus midpoint.

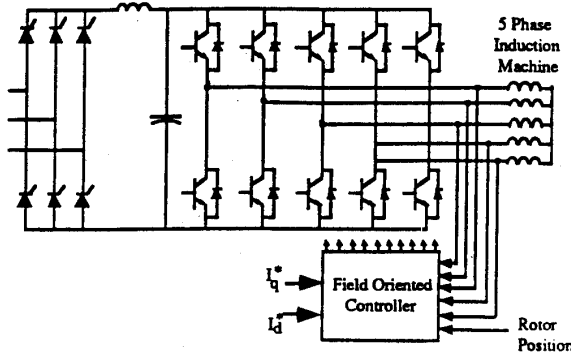

Fig. 2. Five-phase current-regulated PWM inverter drive.

required or not is also important. The phase angle of the current is not a concern as long as a rotating MMF can be generated. In this section, a general approach is introduced to find this optimum solution.

The open circuit analysis of an  $n$ -phase machine can be approached as follows.

1) After one phase of an  $n$ -phase machine is open circuited, the constraints required to maintain a rotating MMF are

$$\begin{aligned} & \cos(2\pi/n)I_2 + \cos(4\pi/n)I_3 + \cos(6\pi/n)I_4 \\ & + \cos(8\pi/n)I_5 + \dots + \cos[2(n-1)\pi/n]I_n \\ & = (n/2)I \cos \theta \end{aligned} \quad (1)$$

$$\begin{aligned} & \sin(2\pi/n)I_2 + \sin(4\pi/n)I_3 + \sin(6\pi/n)I_4 \\ & + \sin(8\pi/n)I_5 + \dots + \sin[2(n-1)\pi/n]I_n \\ & = (n/2)I \sin \theta \end{aligned} \quad (2)$$

From the phasor point of view, a current phasor can be obtained by the sum of two other phasors. Hence, it can be assumed that

$$\mathbf{I}_n = ix_n - jy_n = x_n \cos \theta + y_n \sin \theta \quad (3)$$

where  $n = 2, 3, 4, 5, \dots, n$ .

Separating the  $\cos \theta$  and  $\sin \theta$  components and taking  $I$  as a per unit value, we have following four equations:

$$a_2x_2 + a_3x_3 + a_4x_4 + a_5x_5 + \dots + a_nx_n = n/2 \quad (4)$$

$$a_2y_2 + a_3y_3 + a_4y_4 + a_5y_5 + \dots + a_ny_n = 0 \quad (5)$$

$$b_2x_2 + b_3x_3 + b_4x_4 + b_5x_5 + \dots + b_nx_n = 0 \quad (6)$$

$$b_2y_2 + b_3y_3 + b_4y_4 + b_5y_5 + \dots + b_ny_n = n/2 \quad (7)$$

where

$$a_n = \cos[2(n-1)\pi/n]$$

$$b_n = \sin[2(n-1)\pi/n].$$

The goal is to find  $I_n$  so that the maximum of  $\sqrt{x_n^2 + y_n^2}$  is minimum.

2) Additional reasonable assumptions are as follows.

a) No neutral is required, so that

$$x_2 + x_3 + x_4 + x_5 + \dots + x_n = 0 \quad (8)$$

$$y_2 + y_3 + y_4 + y_5 + \dots + y_n = 0. \quad (9)$$

b) for minimum stator copper loss it is expected that each winding should have the same current magnitude, so that

$$x_2^2 + y_2^2 = x_3^2 + y_3^2 \quad (10)$$

$$x_3^2 + y_3^2 = x_4^2 + y_4^2 \quad (11)$$

$$x_4^2 + y_4^2 = x_5^2 + y_5^2 \quad (12)$$

$$x_5^2 + y_5^2 = x_6^2 + y_6^2 \quad (13)$$

...

$$x_{n-1}^2 + y_{n-1}^2 = x_n^2 + y_n^2. \quad (14)$$

With the above assumptions, the original problem becomes a set of  $n+4$  equations with  $2(n-1)$  unknowns.

This approach can also be used for the case of a machine with any phase number. However, in the case of a three-phase machine, it can be noted that there exist four unknowns and seven equations. There is no additional freedom to allow the neutral current to be zero. Hence, a neutral connection is required in the case of a three-phase machine [1].

### III. ANALYSIS OF MACHINE WITH AN ODD NUMBER OF PHASES

#### A. Five-Phase Motor

A simple means for realizing a uniformly rotating wave with four of the five phases under control can be accomplished by consideration of the zero-sequence component. Since a zero-sequence component of armature current will not produce net airgap flux, and hence, no net flux linking the rotor, a zero-sequence component can be added to all of the remaining four phases, and the rotating MMF of the machine will not be changed. To maintain the rotating MMF after one phase is open circuited, a zero-sequence component with magnitude the same as and phase angle opposite to the interrupted phase is introduced. A zero-sequence component can be added to a balanced five-phase current set to achieve an open-circuited condition. The phasor diagram of the remaining

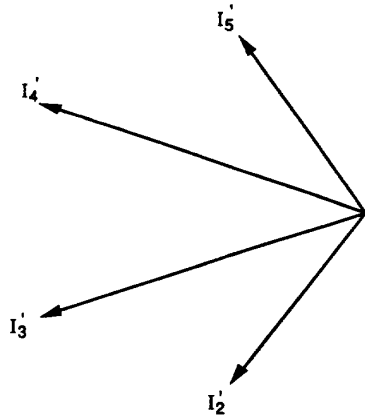

$$\begin{aligned} I_2' &= 1.176 I \cos(\theta - 7\pi/10) \\ I_3' &= 1.902 I \cos(\theta - 9\pi/10) \\ I_4' &= 1.902 I \cos(\theta + 9\pi/10) \\ I_5' &= 1.176 I \cos(\theta + 7\pi/10) \end{aligned}$$

Fig. 3. Phasor diagram of the remaining four phases that will keep the rotating MMF unchanged after phase  $a$  is open circuited.

four phases that will maintain the rotating MMF unchanged after phase  $a$  is open circuited is shown in Fig. 3.

The current phasors shown in Fig. 3, if appropriately applied the remaining four phases of a five-phase machine, will also produce a rotating MMF with the same amplitude and phase as the one produced by a balanced five-phase current set. However, while simple to implement it is unfortunately not a good choice. In particular, it can be noticed that this choice of current implies the necessity of increasing the current of two phases to values as high as 1.9 times their original values. Furthermore, the current magnitudes in the remaining phases are not all the same. Fortunately, the solution for generating the same rotating MMF is not unique. From the analysis in Section II, it can be determined that there are two constraints on the rotating field in the real and imaginary components, respectively. In the three-phase case, with two equations and two unknowns, the solution is unique. However, in a five-phase machine, there are still four remaining stator currents that can be individually controlled. With two equations and now four unknowns, it is clear that the solution is not unique. For an optimum solution it is desirable to have a set of currents that will generate the same rotating MMF with the minimum possible current magnitude for all phases. The following shows an approach to achieve this result.

The MMF in a five-phase machine can be depicted by the equation

$$\text{MMF} = NI_1 + \mathbf{a}NI_b + \mathbf{a}^2NI_c + \mathbf{a}^3NI_d + \mathbf{a}^4NI_e \quad (15)$$

where, in this case  $\mathbf{a} = 1/\sqrt{2}$ .

It is readily shown that if the five currents form a balanced, positively rotating set, then, under normal bal-

anced operation,

$$\text{MMF} = \frac{5NI}{2} e^{j\theta} \quad (16)$$

where  $\theta = \omega t + \phi$ . Assuming that phase  $a$  suddenly becomes open circuited, then, after the open circuit, the real and imaginary parts of (16) are

$$\frac{5NI}{2} \cos \theta = N(I_b' + I_e') \cos 72^\circ - N(I_c' + I_d') \cos 36^\circ \quad (17)$$

$$\frac{5NI}{2} \sin \theta = N(I_b' - I_e') \sin 72^\circ + N(I_c' - I_d') \sin 36^\circ. \quad (18)$$

In order to eliminate the two degrees of freedom remaining in (17) and (18) it is useful to assume that

$$I_b' = -I_d' \quad (19)$$

$$I_c' = -I_e' \quad (20)$$

whereupon, it can be determined that

$$\begin{aligned} I_b' = -I_d' &= \frac{5I}{4} \left( \frac{\sin \theta}{\sin 72^\circ + \sin 36^\circ} + \frac{\cos \theta}{\cos 72^\circ + \cos 36^\circ} \right) \\ &= 1.38I \cos(\omega t + \phi - 36^\circ) \end{aligned} \quad (21)$$

$$\begin{aligned} I_c' = -I_e' &= \frac{5I}{4} \left( \frac{\sin \theta}{\sin 72^\circ + \sin 36^\circ} - \frac{\cos \theta}{\cos 72^\circ + \cos 36^\circ} \right) \\ &= 1.38I \cos(\omega t + \phi - 144^\circ). \end{aligned} \quad (22)$$

Hence, if an open circuit occurs in a five-phase machine, the current in the remaining four phases can be used to control the torque of the machine without the presence of a negative-sequence or zero-sequence current (i.e., current in the neutral wire of the machine). Fig. 4 shows the phasor diagram of the desired currents for the four remaining healthy phases required to maintain an undisturbed rotating MMF. In this case, the current amplitude of the healthy phases needs to be increased to a value only 38 percent greater than when all five phases are functional. Similar control algorithms can be worked out for an open circuit in any of the other four motor phases.

### B. Seven-Phase Motor

After one phase of a seven-phase machine is open circuited, the constraints for producing a smooth, rotating MMF are

$$\begin{aligned} &\cos(2\pi/7)I_2 + \cos(4\pi/7)I_3 + \cos(6\pi/7)I_4 \\ &+ \cos(8\pi/7)I_5 + \cos(10\pi/7)I_6 + \cos(12\pi/7)I_7 \\ &= (7/2) \cos \theta \end{aligned} \quad (23)$$

$$\begin{aligned} &\sin(2\pi/7)I_2 + \sin(4\pi/7)I_3 + \sin(6\pi/7)I_4 \\ &+ \sin(8\pi/7)I_5 + \sin(10\pi/7)I_6 + \sin(12\pi/7)I_7 \\ &= (7/2) \sin \theta. \end{aligned} \quad (24)$$

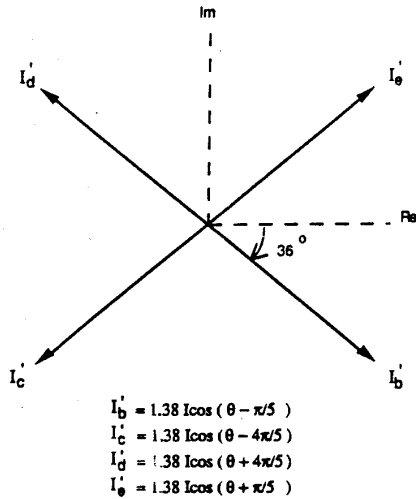

Fig. 4. Phasor diagram of the desired currents for the remaining four healthy phases when phase  $a$  of a five-phase motor is open circuited.

In order to eliminate the three degrees of freedom remaining in (23) and (24), it is useful to assume that

$$I_2 = -I_5' \quad (25)$$

$$I_3 = -I_6' \quad (26)$$

$$I_4 = -I_7' \quad (27)$$

These assumptions actually specify the relationship of the current magnitude and the phase angle of the three pairs of the current. The remaining degrees of freedom can be used to constrain the magnitudes of the phase currents so that all the phase currents have the same magnitude. That is

$$|I_2'| = |I_3'| \quad (28)$$

$$|I_3'| = |I_4'| \quad (29)$$

whereupon, it can be determined that

$$I_2 = -I_5' = 1.233 I \cos(\omega t + \phi - 21.4^\circ) \quad (30)$$

$$I_3 = -I_6' = 1.233 I \cos(\omega t + \phi - 90^\circ) \quad (31)$$

$$I_4 = -I_7' = 1.233 I \cos(\omega t + \phi - 158.6^\circ) \quad (32)$$

Fig. 5 shows the phasor diagram of the desired currents required to maintain the undisturbed rotating MMF for the six remaining healthy phases after one phase of a seven-phase motor is open circuited.

#### IV. SIMULATION RESULTS

The simulation of a five-phase induction motor operated with the proposed strategy when one of its phases is open circuited has been implemented to demonstrate the feasibility of the approach. In this case, phase  $a$  is open circuited. The current commands of the four healthy phases after phase  $a$  is open circuited are controlled to be the values as shown in Fig. 4. Fig. 6 shows the simulation results in which the machine is first accelerated to syn-

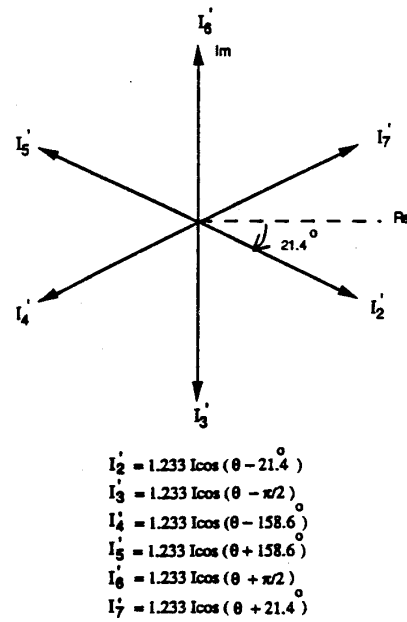

Fig. 5. Phasor diagram of the desired currents for the remaining six healthy phases when phase  $a$  of a seven-phase motor is open circuited.

chronous speed from rest. A sudden changeover from balanced five-phase to symmetric four-phase operation occurs at  $t = 0.4$  s at which point the current amplitudes of the remaining four phases have been increased to 1.38 times their original values as indicated in (22). No disturbance in the speed trace can be noted.

#### V. ANALYSIS OF MACHINE WITH AN EVEN NUMBER OF PHASES

##### A. Four-Phase Motor

For a balanced four-phase motor, it is assumed that the stator currents are controlled to be a balanced positive sequence. From the space phasor point of view

$$\mathbf{I}_a = \frac{I}{2}(e^{j\theta} + e^{-j\theta}) \quad (33)$$

$$\mathbf{I}_b = \frac{I}{2}(\mathbf{a}^{-1}e^{j\theta} + \mathbf{a}e^{-j\theta}) \quad (34)$$

$$\mathbf{I}_c = \frac{I}{2}(\mathbf{a}^{-2}e^{j\theta} + \mathbf{a}^2e^{-j\theta}) \quad (35)$$

$$\mathbf{I}_d = \frac{I}{2}(\mathbf{a}^{-3}e^{j\theta} + \mathbf{a}^3e^{-j\theta}) \quad (36)$$

where

$$\begin{aligned}
 \mathbf{a} &= e^{j\pi/2} \\
 \theta &= \omega t
 \end{aligned}$$

Hence,

$$\begin{aligned}
 \text{MMF} &= \text{MMF}_a + \text{MMF}_b + \text{MMF}_c + \text{MMF}_d \\
 &= N\mathbf{I}_a + \mathbf{a}N\mathbf{I}_b + \mathbf{a}^2N\mathbf{I}_c + \mathbf{a}^3N\mathbf{I}_d \\
 &= 2NIe^{j\theta}
 \end{aligned} \quad (37)$$

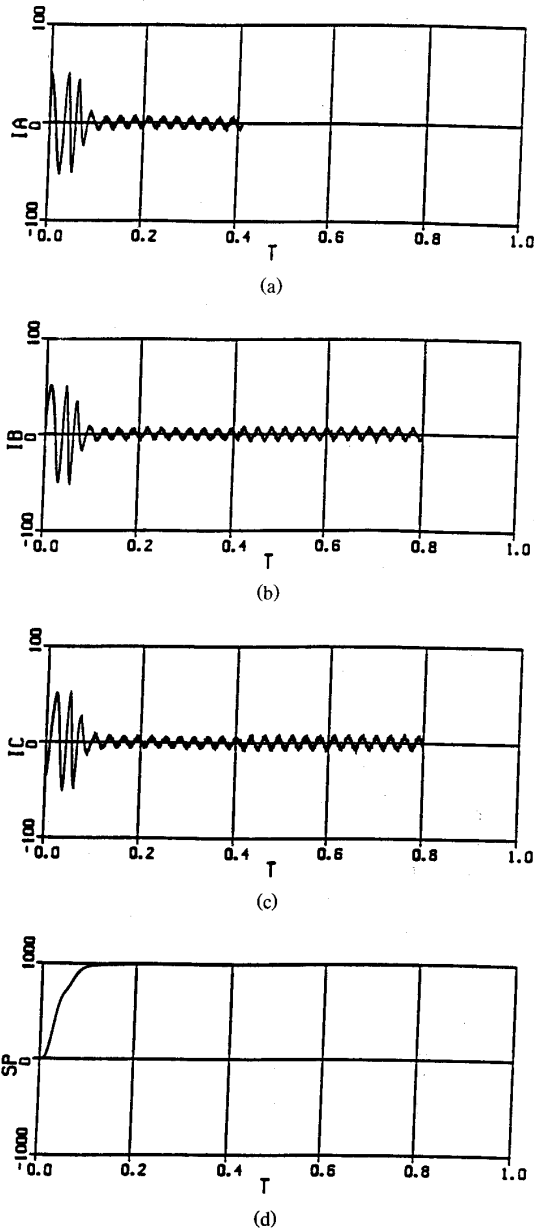

Fig. 6. Computer simulation of current variation after phase  $a$  of a five-phase machine is open circuited. (a) Phase  $a$  current  $I_a$ , (b) phase  $b$  current  $I_b$ , (c) phase  $c$  current  $I_c$ , (d) speed.

The above expression shows that the airgap flux in the four-phase motor is a forward-traveling wave. It can be shown that any multiphase machine energized with balanced currents produces only one unidirectional rotating field. When one phase of a four-phase machine is open circuited, the rotating MMF will be provided by the remaining three phases. In case phase  $a$  is open circuited and the same rotating MMF is to be maintained, then

$$\begin{aligned} \text{MMF} &= N(\mathbf{a}I'_b + \mathbf{a}^2I'_c + \mathbf{a}^3I'_d) \\ &= N[-I'_c + j(I'_b - I'_d)]. \end{aligned} \quad (38)$$

The equation results in two constraints for the three remaining currents, i.e.,

$$I'_c = -2I \cos \theta \quad (39)$$

$$I'_b - I'_d = 2I \sin \theta \quad (40)$$

It is clear that  $I'_c$  now needs to be twice its original current value after phase  $a$  is open circuited. Currents  $I_b$  and  $I_d$  can be arbitrary provided that the relation in (40) is satisfied. A third constraint, requiring minimum amplitude for both the  $b$  and  $d$  phases can be introduced to obtain a unique solution for  $I_b$  and  $I_d$ . Currents  $I_b$  and  $I_d$  can also be controlled to cancel the neutral current, as shown in Fig. 7. Thus, to maintain zero neutral current,  $I_b$  and  $I_d$  must increase to  $\sqrt{2}$  times their original values.

### B. Six-Phase Motor

For a six-phase machine, two types of magnetic field structures are common, and, hence, are considered here. One type has six magnetic field directions evenly separated ( $60^\circ$  electrical phase shift between windings). The other type consists of two sets of three-phase windings, having a  $30^\circ$  electrical phase shift with respect to each other ("dual three-phase" winding).

1) *Evenly Separated Six-Phase Machine:* The field produced by the six-phase machine is also a rotating field. It can be considered as two sets of three-phase windings with a  $180^\circ$  phase shift. Phases 1, 3, and 5 are one set. Phases 2, 4, and 6 are the other set. Hence, the analysis performed in the three-phase motor for one phase open circuited can be applied immediately. If phase 1 is open circuited, one means to keep the rotating MMF the same is to control the current amplitudes and phase angles of phases 3 and 5 as in the three-phase case.

Since the currents are very unbalanced, one can take advantage of having a second set of stator windings to improve the current distribution. From the previous discussion it can be determined that one unit of current increase in set 2-4-6 can be used to reduce, by  $\sqrt{3}$  the current in set 3-5. Hence, it is possible to increase the current in set 2-4-6 and decrease the current in set 3-5 until the currents in both sets are equal. A set of currents with equal magnitude of 1.268 is now achieved as shown by the phasors in Fig. 8.

Unfortunately, this equal magnitude current set will result in a neutral current with a magnitude of 2.2 times its rated value. The general approach discussed in Section II can alternatively be used to achieve a solution without a neutral current.

The solution of the equations as discussed in Section II is a required set of currents for the remaining five phases of a six-phase machine after phase 1 is open circuited. Solution of these equations can again be solved by means of a computer. This solution has the same magnitude for each phase of current and no neutral connection required. Fig. 9 shows the phasor diagram for this solution.

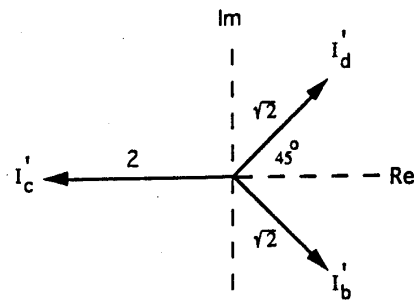

Fig. 7. Phasor diagram of the remaining three phase for zero neutral current when phase *a* of a four-phase machine is open circuited.

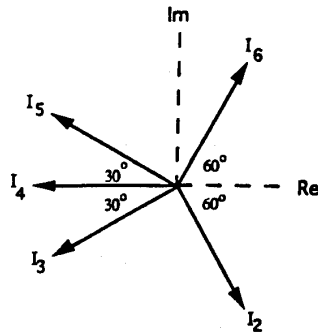

Fig. 8. Phasor diagram of the remaining five phases, which have the same magnitude and will maintain a rotating MMF as unchanged after phase 1 is open circuited.

It is noted that the current magnitude is increased slightly, from 1.268 to 1.297.

2) *30° Displaced Six-Phase Machine*: It is well known that the sixth-harmonic pulsating torque associated with conventional three-phase six-step CSI induction motor drives can be eliminated by a 30° displaced six-phase motor winding configuration, or "dual three-phase" arrangement. If the neutrals of these two three-phase sets are not connected, and the voltage of the 2-4-6 set lags behind the voltage of the 1-3-5 set by 30°, all the airgap flux components of orders  $6n \pm 1$  ( $n = 1, 3, 5, \dots$ ) contributed by the six stator phases cancel each other. Hence, such machines are popular for high-horsepower applications.

By using CRPWM (current regulated pulse width modulation) control, the neutrals of the two three-phase sets need not be separated. In contrast, they should be connected together so that the neutral current can be eliminated when one or more of the stator windings is open circuited. The analysis in Section II can be applied directly to this situation. If a minimum current in the remaining windings is desired, a neutral connection is required. The current phasor in this case is shown in Fig. 10.

If no neutral connection is desired, the solution can be solved by the general approach described in Section V-C1). The constraints needed to realize an unchanged rotating

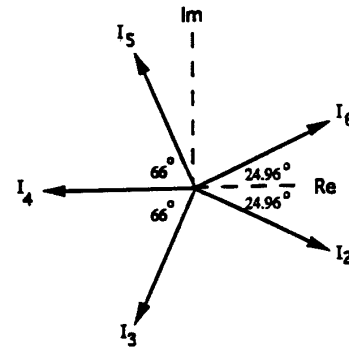

$$\begin{aligned} I_1 &= 0 \\ I_2 &= 1.297 I \cos(\theta - 24.96^\circ) \\ I_3 &= 1.297 I \cos(\theta - 114^\circ) \\ I_4 &= 1.297 I \cos(\theta + \pi) \\ I_5 &= 1.297 I \cos(\theta + 114^\circ) \\ I_6 &= 1.297 I \cos(\theta + 24.96^\circ) \end{aligned}$$

Fig. 9. Preferred phasor diagram of the remaining five phases of a six-phase machine that will maintain the same MMF after phase 1 is open circuited and will result in zero neutral current.

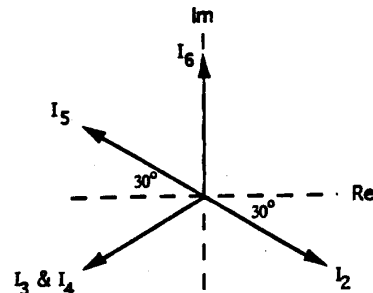

$$\begin{aligned} I_1 &= 0 \\ I_2 &= 1.268 I \cos(\theta - \pi/6) \\ I_3 &= 1.268 I \cos(\theta - 5\pi/6) \\ I_4 &= 1.268 I \cos(\theta - 5\pi/6) \\ I_5 &= 1.268 I \cos(\theta + 5\pi/6) \\ I_6 &= 1.268 I \cos(\theta + \pi/2) \end{aligned}$$

Fig. 10. Minimum current phase diagram of the remaining five phases that have the same magnitude and will keep the rotating MMF unchanged after phase 1 of a 30° displaced six-phase motor is open circuited.

MMF are now

$$0.866x_2 - 0.5x_3 - 0.866x_4 - 0.5x_5 = 3 \quad (41)$$

$$0.866y_2 - 0.5y_3 - 0.866y_4 - 0.5y_5 = 0 \quad (42)$$

$$0.5x_2 + 0.866x_3 + 0.5x_4 - 0.866x_5 - x_6 = 0 \quad (43)$$

$$0.5y_2 + 0.866y_3 + 0.5y_4 - 0.866y_5 - y_6 = 3 \quad (44)$$

$$x_2 + x_3 + x_4 + x_5 + x_6 + x_7 = 0 \quad (45)$$

$$y_2 + y_3 + y_4 + y_5 + y_6 + y_7 = 0 \quad (46)$$

$$x_2^2 + y_2^2 = x_3^2 + y_3^2 \quad (47)$$

$$x_3^2 + y_3^2 = x_4^2 + y_4^2 \quad (48)$$

$$x_4^2 + y_4^2 = x_5^2 + y_5^2 \quad (49)$$

$$x_5^2 + y_5^2 = x_6^2 + y_6^2 \quad (50)$$

The computer solution of the above equations results in a set of currents for the remaining five healthy phases. This solution again has the same magnitude for each current and no neutral connection is required. Fig. 11 shows the phasor diagram of this solution. It is noted that the current magnitude has been increased from 1.268 to 1.44.

VI. COMPARISON OF CURRENT REQUIREMENTS

From the previous analysis, it can be seen that the current requirement for maintaining the same rotation MMF after one phase is open circuited depends not only on the phase number, but also on the construction of the stator. The neutral connection also has effects on the magnitude of required currents. Table I summarizes the results from the previous analysis. Generally speaking, with one phase open circuit, the current is decreased with an increase of the phase number. For a three-phase machine, a neutral connection is necessary. For a four-phase machine, a desired current set of equal magnitude cannot be obtained because of its symmetric construction. In effect, the lost MMF caused by the open-circuited phase cannot be compensated by those windings that are orthogonal to it. Hence, an asymmetrical current is required in a four-phase machine after one phase is open circuited. For a dual three-phase machine, a neutral connection could reduce the current from 1.44 pu to 1.268 pu. Fig. 12 shows the trend of current magnitude and stator copper loss for multi-phase machines with one opened phase.

VII. CONCLUSION

A neutral line connected between the motor neutral and the dc midpoint of a three-phase machine is required after one phase is open circuited if it is desired that the current in the remaining two phases be individually controlled. Hence, a zero-sequence component is required in a three-phase machine to provide for an undisturbed rotating MMF after one phase is open circuited. However, it has been shown in this paper that by using a five-phase or a seven-phase machine, it is possible to take advantage of the additional degrees of freedom as a result of more phases. The current combination required to provide the same rotating MMF after one phase is open circuited is no longer unique. It has been shown that when one phase is open circuited, with appropriate control, the zero sequence current is no longer a necessary component as in a three-phase machine. That is, one can eliminate the need for a neutral line and the machine can still be controlled so as to produce a smooth nonpulsating torque.

It has also been determined that the rating of motor and inverter will both benefit by the use of extra phases. In a three-phase machine, after one phase is open circuited, the motor can continue to operate at the rated torque provided that the current phase angle of the remaining two phases are appropriately controlled and the current magnitude are increased to 1.732 times of the rated current. However, in a five-phase machine, the

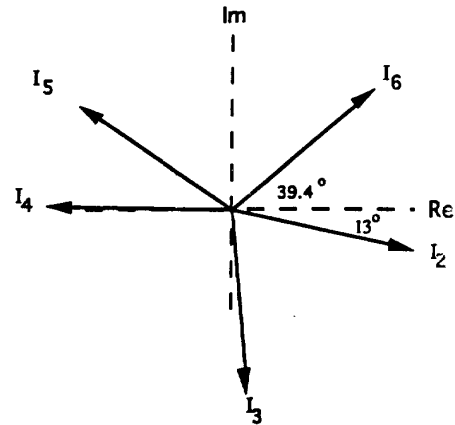

$$\begin{aligned}
 I_1 &= 0 \\
 I_2 &= 1.44 \text{ Icos}(\theta - 13^\circ) \\
 I_3 &= 1.44 \text{ Icos}(\theta - 85.4^\circ) \\
 I_4 &= 1.44 \text{ Icos}(\theta + 178.5^\circ) \\
 I_5 &= 1.44 \text{ Icos}(\theta + 145.8^\circ) \\
 I_6 &= 1.44 \text{ Icos}(\theta + 39.4^\circ)
 \end{aligned}$$

Fig. 11. Phasor diagram of the remaining five phases that will keep the rotating MMF unchanged after phase 1 of a 30° degree displaced six-phase motor is open circuited.

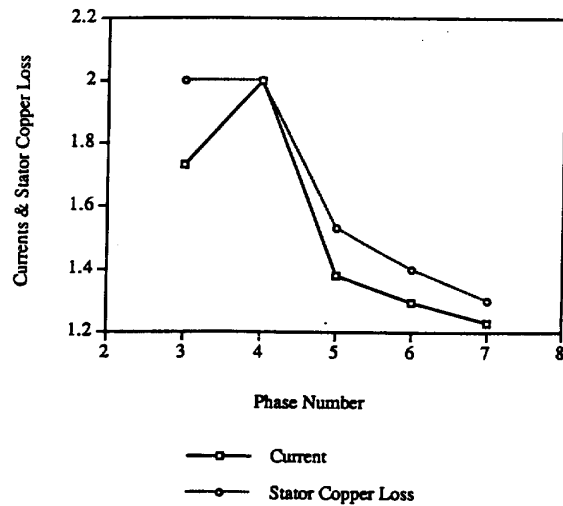

Fig. 12. The trend of current magnitude and stator copper loss for multiphase machines.

TABLE I  
THE CURRENT COMPARISON OF MULTIPHASE MACHINES  
NA = NOT APPLICABLE (I.E., NOT PRACTICAL).

Phase Numbers	w/o Neutral (pu)	w/ Neutral (pu)	Neutral Currents (pu)
3φ	NA	1.732	3
4φ	$2 : \sqrt{2} : \sqrt{2}$	2 : 1 : 1	2
5φ	1.382	NA	NA
6φ	1.297	1.268	2.2
6φ (dual 3 φ)	1.44	1.268	2.2
7φ	1.23	NA	NA

magnitude of the phase current required to provide the same torque can now be only 1.382 times of its rated value. In a seven-phase machine, the ratio can be reduced to 1.233. With this reduced current rating, the proposed one open-phase control strategy becomes quite feasible.

#### REFERENCES

- [1] T. H. Liu, J. R. Fu, and T. A. Lipo, "A strategy for improving reliability of field oriented controlled induction motor drives," *1991 IEEE IAS Annu. Meet. Conf. Rec.*, vol. 1, pp. 449-455, 1991.
- [2] T. A. Lipo and D. W. Novotny, "Dynamics and control of ac drives," (course notes), Univ. Wisconsin—Madison, 1991.
- [3] T. M. Jahns, "Improved reliability in solid-state ac drives by means of multiple independent phase-drive units," *IEEE Trans. Industry Applicat.*, vol. IA-16, pp. 321-331, May/June 1980.
- [4] M. A. Abbas, R. Christen, and T. M. Jahns, "Six-phase voltage source inverter driven induction motor," *IEEE Trans. Industry Applicat.*, vol. IA-20, pp. 1251-1259, Sept./Oct. 1984.
- [5] R. H. Nelson and P. C. Krause, "Induction machine analysis for arbitrary displacement between multiple winding sets," *IEEE Trans. Power App. Syst.*, vol. PAS-93, pp. 841-848, May/June 1974.
- [6] J. D. Cogdell, *Fundations of Electrical Engineering*. Englewood Cliffs, NJ: Prentice-Hall, 1990.
- [7] D. O'Kelly, *Performance and Control of Electrical Machines*. New York: McGraw-Hill, 1991.

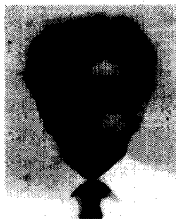

**Jen-Ren Fu** received the B.S. degree in electrical engineering in 1973 from the National Cheng-Kung University, Tainan, Taiwan, the M. Eng. degree in energy technology from the Asia Institute of Technology, Bangkok, Thailand, in 1988, and the Ph.D. degree from the Department of Electrical and Computer Engineering, University of Wisconsin—Madison, in 1993.

He joined the Taiwan Power Company in 1975, where he has been engaged in the engineered safety feature design for nuclear power

plants and the equipment qualification of the safety-related systems. His current research interests include the simulation of electric machines and drives and microprocessor-based real-time control.

Mr. Fu is a Registered Professional Engineer in Taiwan and Wisconsin. He is a member of the Chinese Association for Energy Economists.

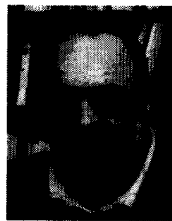

**Thomas A. Lipo** (M'64-SM'71-F'87) is a native of Milwaukee, WI. He received the B.E.E. and M.S.E.E. degrees from Marquette University, Milwaukee, in 1962 and 1964 and the Ph.D. degree in electrical engineering from the University of Wisconsin in 1968.

From 1969 to 1979 he was an electrical engineer with the Power Electronics Laboratory, Corporate Research and Development, General Electric Company, Schenectady, NY. He became a Professor of Electrical Engineering at

Purdue University in 1979 and in 1981 he joined the University of Wisconsin in the same capacity where he is presently the W.W. Grainger Professor for Power Electronics and Electrical Machines.

Dr. Lipo has been engaged in power electronics research for over 25 years. He has been awarded 11 patents, published over 200 technical papers, and has received 17 IEEE prize paper awards for his work, including coreipient of the Best Paper Award in the IEEE Industry Applications Society TRANSACTIONS for the year 1984. In 1986, he received the Outstanding Achievement Award from the IEEE Industry Applications Society for his contributions to the field of ac drives and in 1990 he received the William E. Newell Award of the IEEE Power Electronics Society for contributions to field of power electronics. He is currently the President of the IEEE Industry Applications Society.