

Wisconsin Electric Machines and Power Electronics Consortium

RESEARCH REPORT
93-41

A New Approach to Motor Condition Monitoring in Induction Motor Drives

Shaotang Chen, Erkuan Zhong, Thomas A. Lipo
Dept. of Electrical and Computer Engineering
University of Wisconsin-Madison
1415 Johnson Drive
Madison, WI 53706

WEMPEC

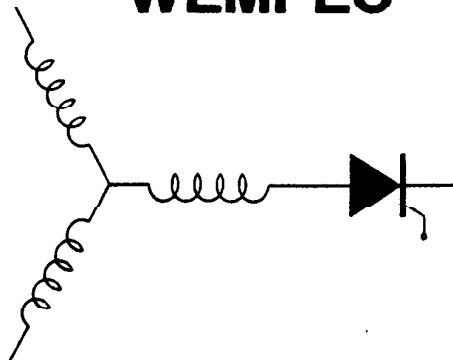

Department of Electrical and Computer Engineering
1415 Johnson Drive
Madison, Wisconsin 53706
© August 1993 Confidential

A New Approach to Motor Condition Monitoring in Induction Motor Drives

Shaotang Chen, Erkuan Zhong, Thomas A. Lipo
Department of Electrical and Computer Engineering
University of Wisconsin-Madison
1415 Johnson Drive
Madison, WI 53706-1691 USA

Abstract - A new method for condition monitoring of an electrical machine is proposed. The method uses the power leads of the machine itself as the communication link between the sending station located within the machine and the receiving station located remotely outside the machine. The required communication circuit to realize data transmission in both the case of the ordinary 60 Hz power line and the special PWM inverter-fed power line is constructed. The communication circuit uses an asynchronous serial communication protocol and a FSK modulation for realizing frequency multiplexing in the power line. An on-line winding temperature monitoring system for an inverter-fed induction machine is constructed using this power line communication link. Experimental results demonstrate satisfactory operation of the system.

I. INTRODUCTION

On-line condition monitoring of an electric machine has become a area of increasing interest and importance to electrical utilities and process industries. Owing to its effectiveness in preventing catastrophic failures of a machine and reducing maintenance costs, condition monitoring has been proved as a viable means to improve system reliability and to reduce the overall system cost, especially in large machines [1].

While most of the research efforts have been focused on the implementation of a variety of monitoring techniques to obtain as many meaningful machine operating parameters as possible, it is obvious that transmission of monitoring data can become even more important and cost involved when a monitoring or control station is to be located remotely from within a machine. For example, in concentrated monitoring centers in process and mining industries where access to machines is dangerous or prohibited, data communication plays an important role in system operation. The installation of an additional data communication network becomes very inconvenient and often adds considerable cost to the monitoring system. Therefore, there remains a considerable opportunity for improving the performance of a monitoring system in the design of a suitable communication link.

As is well known, the electric power transmission line has been utilized to carry communication signals by electrical utility companies for more than sixty years[2]. Recently, the low voltage intrabuilding power distribution line has also been explored extensively for replacing special communication cables for computer local area network

(LAN), load management and telemetering, office and home automation, etc [3,4,5]. The major advantages of using the power line as a communication link are the elimination of substantial costs involved with cable installation and maintenance, simplification of system configuration, and the use of a simple and standard communication interface in the form of wall-socket plug. The penalties are an increase of the transmitter and receiver circuit topologies and the use of more complicated signal transmission and recovering techniques. However, these problems have been alleviated greatly by today's advanced signal processing and LSI techniques. And considerable gains in overall advantages vs. disadvantages have been obtained in more and more areas through employment of power line communication (PLC) techniques.

It is obvious that the PLC techniques will also bring considerable benefits and changes to condition monitoring of electrical machines. Due to the increasing tendency of using on-line machine condition monitoring to reduce operation costs and to increase reliability [6], an increasing importance of power line communication in electrical machine applications can also be observed. Also, an ever increasing number of feedback channels from the machine's terminal conditions are required for high efficiency and high performance control operations. In other words, today's requirements for machine condition monitoring, field orientation control and high performance drive and power converter techniques are all becoming increasingly dependent on communication requirements between the machine and a suitable monitoring or control station. Therefore, utilization of a power line communication link could open a new field of research for electrical machine monitoring and control.

The introduction of power line communication techniques leads to the concept of a new condition monitoring system using power line as a communication link as shown in Fig. 1. The sending station, which is located inside the machine itself, will make the machine become 'smart' with self diagnostic and talking capabilities which can be activated merely by connecting a receiving station to the power line. Such a package inside a machine will also enable existing converters or drives to improve their performance by receiving additional feedback information without major structural alteration and external wiring connections.

Although data communication through the 60 Hz ordinary power line has been successful in various applications, challenges still exist in electrical machine

applications, challenges still exist in electrical machine applications. In particular, due to the extensive use of inverters to drive an electric machine, it would be desirable to extend the power line concept to include the PWM inverter as a power source. However, as is analyzed in Section II, there exist intrinsically different transmission characteristics between an ordinary 60 Hz power line and a PWM inverter-fed power line. The ordinary PLC technique must be extended to the special case of a PWM inverter-fed power line in order to realize this new condition monitoring system concept.

In section III, such a prototype communication circuit is developed and the monitoring system as shown in Fig 1 is constructed. The new PLC system is similar to that of an ordinary PLC, but special considerations regarding the rejection of PWM harmonics and noise and special signal recovering techniques are incorporated. Experiments are carried out using this system to monitor the stator winding temperature of an induction machine. The results are shown in Section IV.

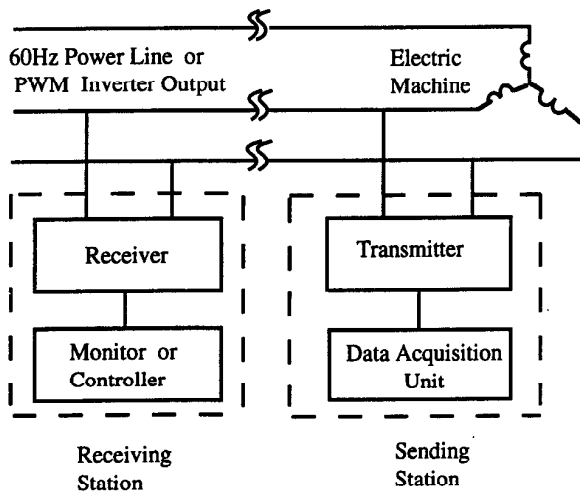

Fig. 1 A New Monitoring System Using Power Line as a Communication Link

II. TRANSMISSION CHARACTERISTICS OF A PWM INVERTER-FED POWER LINE

To realize the proposed monitoring system, it is necessary to answer the question as to whether it is feasible to use the power line for data transfer purposes, i.e. the transmission characteristics of the power line for data communication must be investigated. Fortunately, extensive studies of the transmission characteristics of the 60Hz distribution line have already been performed [7,8]. The basic conclusion is that although the power line is not an optimal environment for communication, it is feasible for transmission of high frequency communication signals up to 100 MHz.

For a PWM inverter-fed power line, the transmission characteristics is completely different. This is because the inverter output voltage basically consists of pulses or square waves with variable frequency and duration. Thus, it

requires much wider spectrum for power delivery. Another distinctive difference is that the 60Hz power line is the output of a transformer or a generator, while the output of a PWM inverter-fed power line is the output of transistors or switching components, which results in different impedance characteristics.

For a typical sinusoidal PWM inverter, the output line voltage possesses a spectrum as shown in Fig. 2. In comparison with the 60 Hz power line, which has only a single fundamental frequency at 60 Hz, large amounts of switching frequency harmonics exist from several kHz to several hundred kHz.

While the amplitude of frequency components above several hundred kHz is small, it is possible to utilize this high frequency band for communication purposes based on frequency multiplexing theory as shown in Fig. 2.

For frequency multiplexing, an ideal filter is assumed available to separate all PWM frequency components from the communication signals. In practice, two facts make it difficult to construct such a filter:

1. Due to the extremely high amplitude of the switching noises, which is as high as the DC link voltage, an almost infinite attenuation would be required for the filter to reduce the PWM harmonics to an insignificant level.
2. Due to the parasitic effects and the switching frequency which is as high as several kHz with a magnitude of several hundreds volts, the switching noise would couple through the parasitic capacitors and directly enter the output of the filter.

Thus, it will not be surprising to find from section IV that all the communication signals are deeply buried in the PWM noise, no matter what type of filter are used. It is therefore a challenge for the design of a communication link in such a hostile environment.

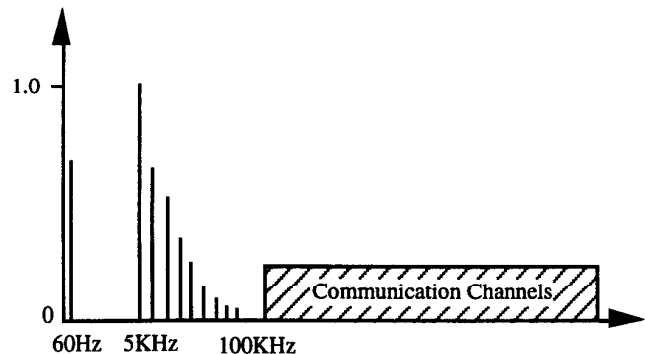

Fig. 2 Transmission Characteristics of a Typical PWM Inverter-Fed Power Line

III. NEW MONITORING SYSTEM CONFIGURATION

The analysis of the PWM inverter-fed power line transmission characteristics leads to the system as shown in Fig. 2 to realize communication in a sinusoidal PWM inverter-fed power line and thus implement the new condition monitoring system configuration. From the view point of spectrum analysis the 60 Hz power line can be

Hence, the communication link presented here will also operate on the 60Hz power line. Nevertheless, we will confine our discussion in this paper to the case involving a PWM inverter-fed power line.

The new monitoring system is divided as a sending station which is located inside the motor itself and a receiving station located remotely outside the motor. The sending station consists of a data acquisition unit to obtain the monitored operation parameters, a transmitter to send the encoded carrier through the power line and a microcontroller to encode the data using asynchronous serial communication protocol and to coordinate the work of the data acquisition unit. The receiving station consists of a receiver to recover the carrier signal from the power line, a microcontroller to decode the data and a monitor to display the received data or a controller to process the data for control purpose.

The communication link of the system uses a line coupling principle similar to that used in ordinary power line communication circuits. The line coupling circuit is used to block the low frequency PWM waves in the power line while providing a path for high frequency communication carrier to the power line. The carrier frequency is selected by using frequency division or multiplexing techniques. In our prototype implementation with a sinusoidal PWM inverter with a switching frequency equal to 6 KHz, it was calculated that the optimal carrier frequency is 5 MHz

Frequency division principles, however, suggests that only carrier frequencies higher than several hundred kilohertz are feasible for transfer to ensure sufficient margin for separation with the PWM waves. However, the requirements for data rate are considerably different from one case to another. It is therefore necessary to use special modulation techniques to encode the data into carrier signals. In the prototype link, the frequency shift keying (FSK) modulation is used. The carrier is chosen as sinusoidal wave so that less EMI is achieved.

A. Transmitter

A prototype circuit of transmitter, shown in Fig. 3, accepts serial data from a microcontroller. The NE5080 FSK modulation IC generates a sinusoidal carrier frequency according to the data in its input pin. If the data input is '1' it produces a frequency of 6.5MHz carrier at its output, and if the data is '0' the it produces a frequency of 3.5MHz. The FSK outputs a 1 Vp-p. signal, which is too small to reject the PWM switching impulse noise and to accommodate the line impedance variation. Thus, a booster circuit utilizing a class B amplifier is employed to magnify the signal amplitude and provide drive ability. The line coupling circuit, which consists of a high frequency transformer and two capacitors, is basically a high pass filter such that the modulated FSK carrier signal will pass with very small attenuation. The other function of the line coupling is to provide an impedance matching between the booster output and the power line.

B. Receiver

The prototype receiver circuit to recover the transmitted communication signal from the power line is shown in Fig 4. Its function is to select the communication carrier signal

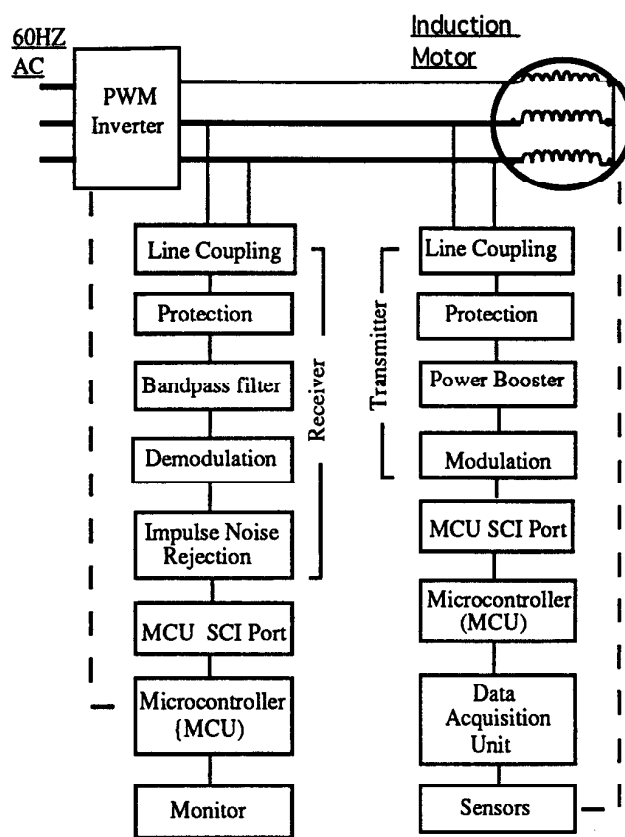

Fig. 3 Schematic of the New Motor Condition Monitoring System

from the power line, decode the data from the carrier and then output data to the monitor or controller. The line coupling network is similar to that of the transmitter for passing only the carrier signal and providing impedance matching. Since the power line noise presented at the receiver transformer secondary can be as high as 70 Vpp, a ten pole Butterworth bandpass filter is designed to select the communication channel frequency to reduce its effects. The signal is then sent to the FSK demodulation circuit NE5081, which outputs a digit "1" at its output pin if the received frequency is 6.5MHz or "0" if the frequency is 3.5 MHz. As the line impulse noise also presented at the decoded data signal, complicated digital or analog filtering techniques are incorporated to discriminate noise from the data.

C. Data acquisition unit

The data acquisition is performed by the A/D submodule of the MCU or the Motorola MC68HC16 microcontroller. In the prototype circuit only machine winding temperatures are monitored. The temperature measurement uses an LM335 integrated temperature sensor. The interface is shown in Fig. 6. Winding temperature data is then sampled by the MCU, converted into serial asynchronous data by the MCU serial communication port and then sent to the transmitter modulation circuit.

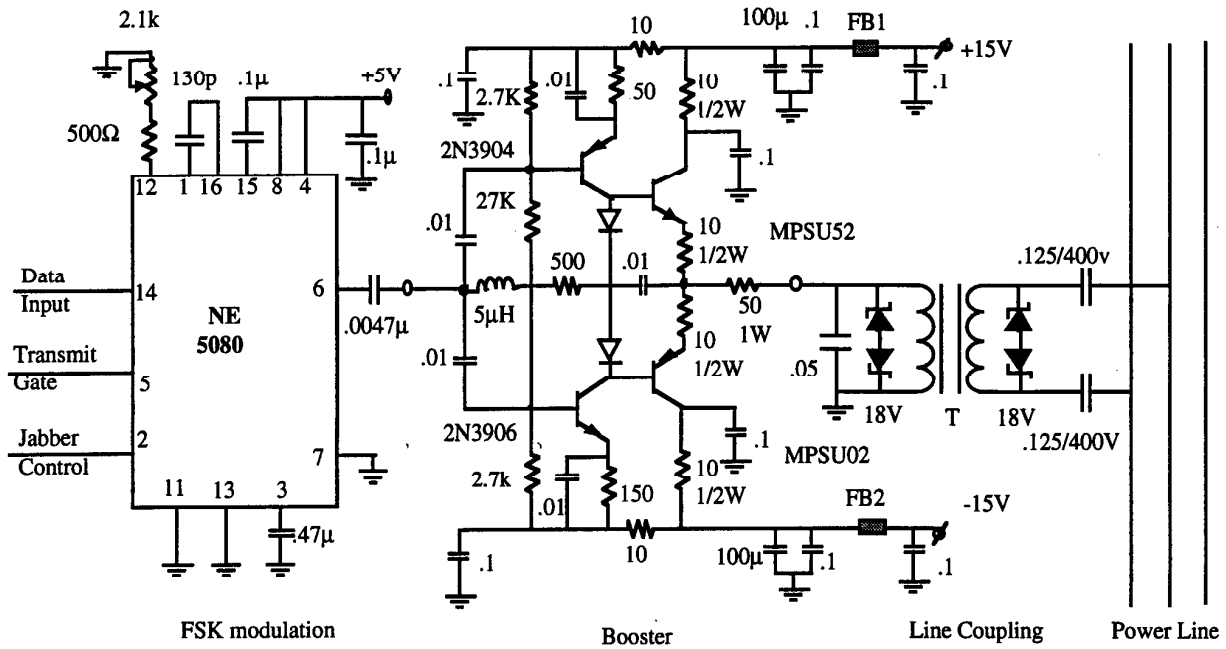

Fig. 4 Prototype Transmitter Circuit

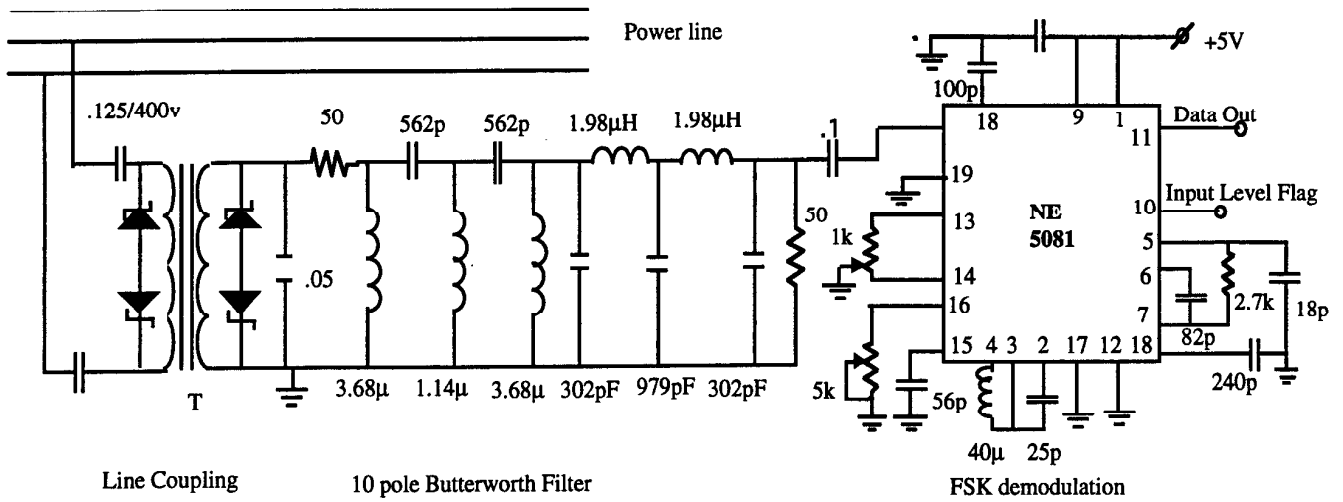

Fig 5 Prototype Receiver Circuit

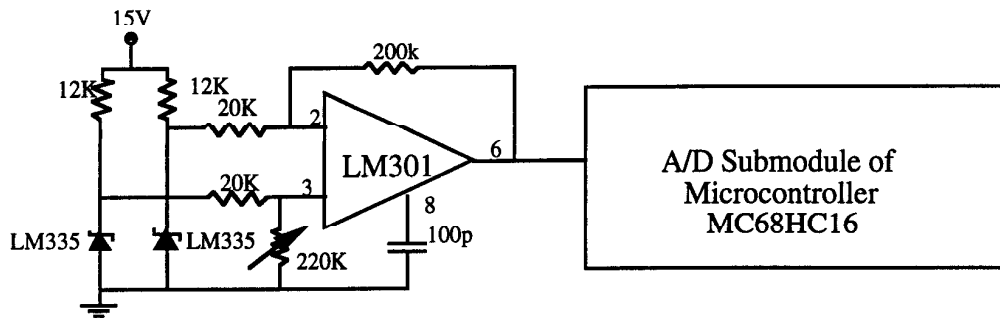

Fig 6 Data Acquisition Circuit for Winding Temperature Measurement

IV. EXPERIMENTAL RESULTS

Typical transmitter waveforms are depicted in Fig. 7. The impulse noise corresponds to the PWM switching action. For each PWM switching action, there is one impulse noise produced. The impulse noise is so strong that even after passing through the line coupling circuit, its amplitude still far exceeds the Zener limit of the protection circuits. Because the impulse noise also enters the output

of the transmitter, it causes corruption of the communication signal at each PWM switching instant. A close view of the transmitter waveforms shown in Fig. 7b demonstrates that the transmitter ceases to function properly during each PWM switching interval. Thus, it is obvious that no communication signals are actually transmitted during the PWM switching intervals. Fortunately, for a baud rate up to 9600 bps, the duration for each data bit will be much longer than a PWM switching interval. This makes it possible for the receiver to use filtering to smooth the received data signals.

The receiver signal waveforms are plotted in Fig. 8. These traces demonstrate that they are also corrupted by the PWM switching noise. As the impulse noise is resulted from the PWM switching harmonics, it has extremely large amplitude, the noise can not be attenuated effectively by a filter. Also, due to its high frequency components, the PWM noise can couple directly into the output of the filter through the parasitic or distributed capacitors. Therefore, it is found that the PWM noise is also present at almost any point of the receiver circuit. Even after the demodulation circuit one can still find that the decoded data signal is actually buried under the PWM switching noise. Thus, an impulse discrimination circuit is required to recover the data signals from the noise. Such an impulse noise discrimination circuit can be formed by using a low pass filter or a digital filtering algorithm. In our experiment, both of circuits have been tested to be able to operate satisfactorily for the purpose of recovering transmitted data. An output of the recovered data from the impulse noise discrimination filter is included in trace 4 of Fig. 8.

To demonstrate the operation of the new condition monitoring system, the winding temperature of a 10 HP induction motor has been monitored. The winding temperature is measured by the LM335 temperature sensors, digitized by the A/D port of the MCU and then sent by the transmitter into the power line. The induction motor is driven by a sinusoidal PWM inverter with a 6 KHz switching frequency. The length of the power line from the inverter to the motor was 250 feet. The receiving station was located at the end of the 250 foot line near the inverter. Data communication signals were picked up by the receiver from this inverter-fed power line, decoded and recovered using the impulse noise discrimination circuit. The recovered data was then sent to a dummy terminal in our experiments for the purpose of displaying the winding temperature. While not practical to show the results in pictorial form, it has been found that the monitoring system functions very satisfactorily with a transmission baud rate up to 9600 bps. The bit error rate at low baud rate has been verified to be smaller than 10^{-6} . However, with the increase of data baud rate the bit error rate will also increase and become equal to 10^{-5} at a baud rate of 9600 bps which is still adequate for fast, reliable data transfer.

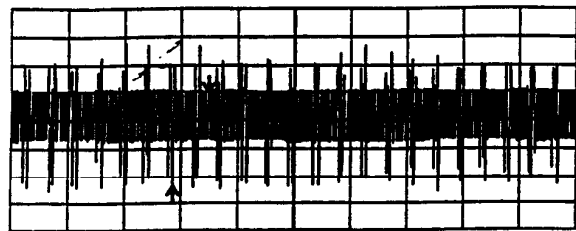
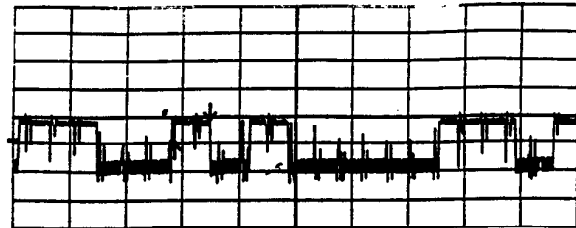

a) With Data Baud Rate=9600bps

Upper: wave measured at Data Input Pin
Bottom wave measured at transformer T primary

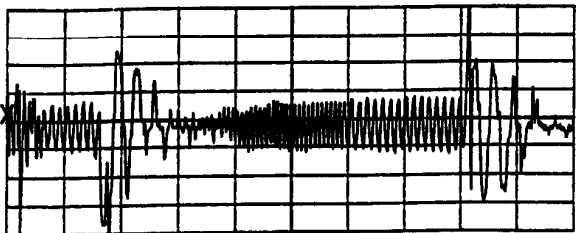
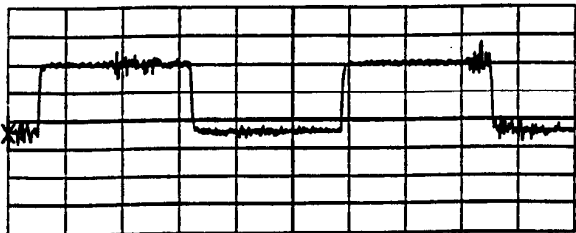

b) A Close View of Waveform
When Transmitting a 100KHz Square Wave Signal

Upper wave measured at Data Input Pin
Bottom wave measured at transformer T primary

Fig. 7 Transmitter Waveforms

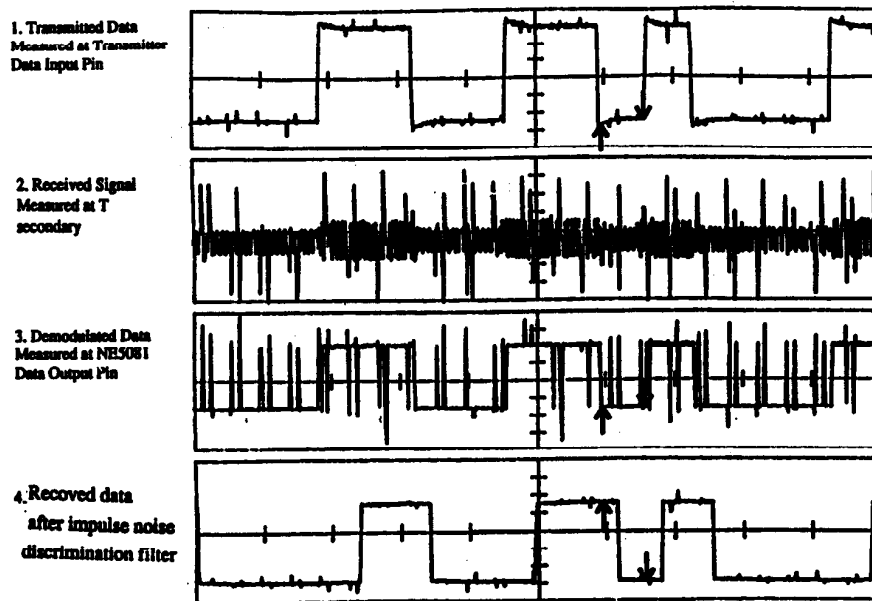

Fig. 8 Receiver Waveforms with a Data Baud Rate of 9600 bps

V. CONCLUSIONS

A new condition monitoring system using the power line as a communication link has been proposed in this paper. A major finding of this work is that it is possible to transfer data along the output terminals of a PWM inverter. Thus, the power line communication techniques are extended for the first time to the inverter-fed power line. The communication link prototype developed is demonstrated by experiments to be able to operate satisfactorily up to a baud rate of 9600 bps. Based on this novel communication link prototype, an induction machine winding temperature monitoring system is constructed. Successful on-line condition monitoring and data transfer through the inverter-fed power line have been carried out by experiments.

VI. ACKNOWLEDGMENT

The Wisconsin Electric Machines and Power Electronics Consortium (WEMPEC) is gratefully acknowledged for support of this work.

REFERENCES

- [1] D.J.T. Siyambalapatiya and P.G. McLaren, "Reliability Improvement and Economic Benefits of On-Line Monitoring System for Large Induction Machines", *IEEE Trans. Indust. Appl.*, Vol. IA-26, No. 6, 1990, pp. 1018-1025.
- [2] J. Nevel. "History and theory of ripple communication system." Proc. Nat. Telecommun. Conf., Dallas, TX, Nov. 29, Dec. 1, 1976, pp. 2.3.1-2.3.6.
- [3] J. E. Goodman, "Intra company communication network", *Proc. Conf. Electron. Office*, London, England, Apr. 22-25, 1980, pp. 147-157.
- [4] B. D. Russell, "Communication alternatives for distribution, metering and load management", *IEEE Trans. Power App. Syst.*, Vol. PAS-99, 1980, pp. 1488-1455.
- [5] P. K. Van Der Gracht and R. W. Donaldson, "Communication using pseudonoise modulation on electric power distribution circuits", *IEEE Trans. on Communications*, Vol. COM-33, No. 9, 1985, pp. 964-974.
- [6] P. J. Tavner, "Condition monitoring - the way ahead for large electrical machines", *Proc. 4th Intern. Conf. on Electr. Machine and Drives*, London, England, Sept. 13-15, 1989, pp. 159-162.
- [7] A. A. Smith, "Power line noise survey", *IEEE Trans. on Electromag. Compat.*, Vol. EMC-14, Feb. 1992, pp. 31-32.
- [8] M. Tanaka, "Transmission characteristics of a power line used for data communications at high frequencies", *IEEE Trans. on Consumer Electronics*, Vol. 35, No.1, Feb. 1989, pp. 37-42.