

# Controlled Shunt Capacitor Self-Excited Induction Generator

Mustafa A. Al-Saffar  
Dept. of Electrical Engineering  
College of Technological Studies  
P.O. Box 39525  
Al-Nuzha, Kuwait 73056  
Tel : (965) 484-7100  
Ext.: 4317  
Fax : (965) 564-8144  
email: alsaffar@paaet.edu.kw

Eui-Cheol Nho  
Dept. of Electrical Engineering  
College of Engineering  
Pukyong National University  
San 100, YongDang-Dong, Nam-  
Ku, Pusan, 608-739, Korea  
Tel : +82-51-620-1439  
Fax : +82-51-620-1420  
email: nhoec@dolphin.pknu.ac.kr

Thomas A. Lipo  
Dept. of Electrical Engineering  
College of Engineering  
University of Wisconsin-Madison  
1415 Engineering Drive  
Madison WI 53706-1691  
Tel : (608) 262-0287  
Fax : (608) 262-1267  
email: lipo@engr.wisc.edu

**Abstract** This paper proposes a new self-excited induction generator (SEIG) voltage regulation scheme. The proposed SEIG scheme utilizes the concept of a continuously controlled capacitor and is called the controlled shunt capacitor SEIG. An anti-parallel IGBT switches are used across the fixed excitation capacitors to regulate the voltage across a 7.5 HP induction generator. The experimental results and those obtained by simulation are similar. The experimental results are proven that the controlled shunt capacitor SEIG maintains a constant terminal voltage over wide variety of loads and changes in speed, and hence is a reliable and cost effective electric generator controlled system.

## I. INTRODUCTION

It is well known that a conventional induction motor can work as a generator if a sufficient amount of capacitance is connected across the machine terminals to sustain the excitation requirement, while the rotor speed is maintained by some mechanical power [1].

The advantages of using standard three phase squirrel cage induction machine as a self-excited induction generator, SEIG over synchronous alternator are the lower cost due to their simple construction, and the lower maintenance requirements due to their ruggedness and to avoid using brushes. Also, one does not need a separate source for dc excitation current which is required for synchronous alternator. The other advantage is the inherent over load protection. At the occurrence of fault, the current will be limited by the excitation, and the machine voltage will collapse immediately.

However, the SEIG has a serious voltage regulation problem when load and/or speed changes. The remedy to this problem is associated with the need of a continuous supply of the necessary leading VARs instead of the existed fixed excitation capacitor. The variable leading current is needed to balance the lagging currents of the magnetizing current and the given load currents at different power factor for a given rotor speed.

## II. VAR GENERATORS

A wide variety of VAR generators have been used with SEIGs. One VAR generator category uses passive elements. One scheme of this category uses additional capacitor in series with the load [2], or in series with the stator winding [3]. These schemes have limited capability of a continuous voltage regulation over a range of load and/or speed.

The other category is the static VAR generator which uses solid state power switches. Some of the schemes under this category utilize the concept of the thyristor switched capacitor, or the inductively loaded AC/DC converters[4] or the thyristor controlled reactor [5]. Most of these static VAR generators are expensive and have complex control, beside the need of bulky inductors and large excitation capacitors for those capable only of supplying lagging current.

## III. PROPOSED SCHEME

The proposed method for regulating the load voltage is called the controlled shunt capacitor SEIG. Its simplified block diagram is illustrated in Fig. 1. Its per-phase equivalent circuit is shown Fig. 2, where the power switches used are GTO switches. This scheme uses the concept of a continuously controlled capacitor [6]. Where the controlled capacitor consists of a fixed capacitor in parallel with anti-parallel GTO switches. The apparent value of the fixed capacitor can be adjusted periodically by controlling the time in which the capacitor is connected to the circuit. When the GTO switch is turned-off, the current will flow through the capacitor. At the instant the capacitor voltage reaches zero, the switch is turned-on for a short period. Hence, a zero-voltage switching operation is performed.

During the shorting period, the current bypasses the capacitor and the voltage across the capacitor remains at zero. The longer the shorting period, the lower the fundamental component of the voltage across the capacitor and the higher the effective capacitance independent of the current flowing

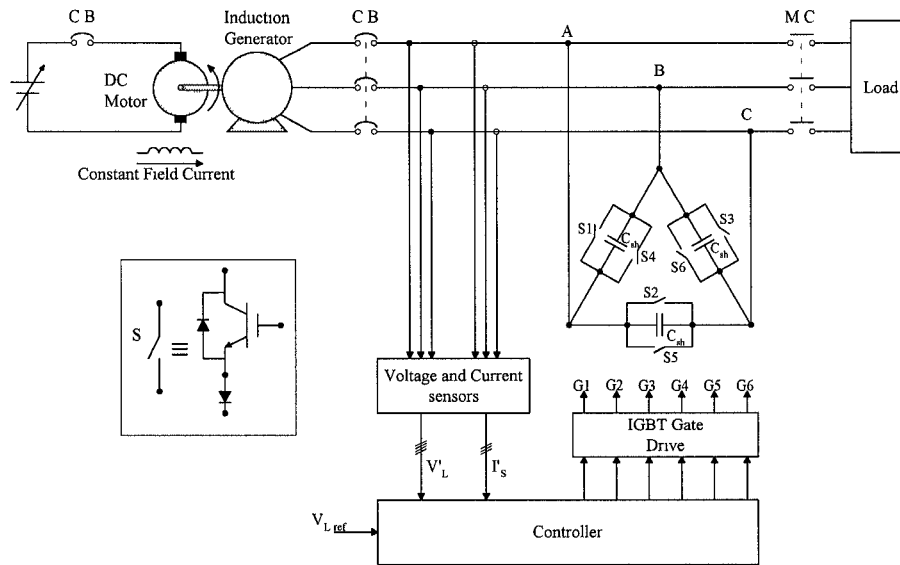

Fig.1. The schematic block diagram of the controlled shunt capacitor SEIG.

through it. Therefore, the minimum apparent capacitance is the actual value of the fixed capacitor while the upper limit is infinity when the shorting time takes over the complete half cycle.

different types of load power factor. While Fig. 6, shows that the machine current is the same for all the load power factors and the machine can deliver its rated power without exceeding its rated current.

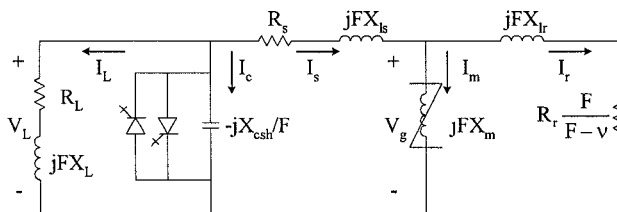

Fig.2 . Equivalent of the controlled shunt capacitor SEIG.

#### IV. SEIG WITH A FIXED EXCITATION CAPACITOR

In order to realize the need of a variable capacitor, one needs to investigate the SEIG with a fixed excitation capacitor. This can be accomplished using the circuit in Fig. 2, without the GTO switches. The “Newton-Raphson” method [7] and the saturation curve of the induction machine given in Appendix are used to solve for  $X_m$ ,  $F$  and the air gap voltage  $V_g$ .

Fig. 3, shows a family of load characteristic curves, for a range of excitation capacitance values at a synchronous speed and a unity power factor load. Based on Fig. 3, a higher excitation capacitance is required in order to reach the machine rated power,  $P_{out}=1.0pu$ . On the other hand, Fig. 4, shows a family of load characteristic curves, for different load power factors at fixed excitation capacitor and at synchronous speed. Fig. 4 shows that the voltage regulation is degraded as the load power factor decreases. This effect is clearly shown in Fig. 5, which illustrates the required excitation capacitor to maintain constant terminal voltage for a SEIG that is running at synchronous speed and supplying

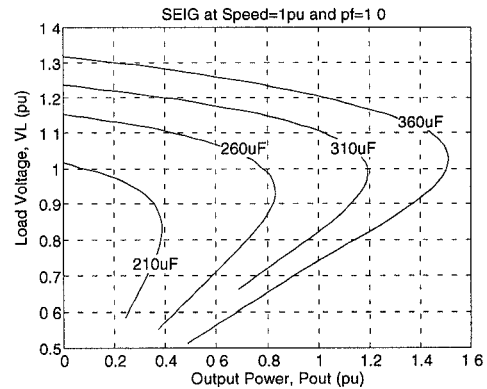

Fig.3 . Effect of Excitation capacitor.

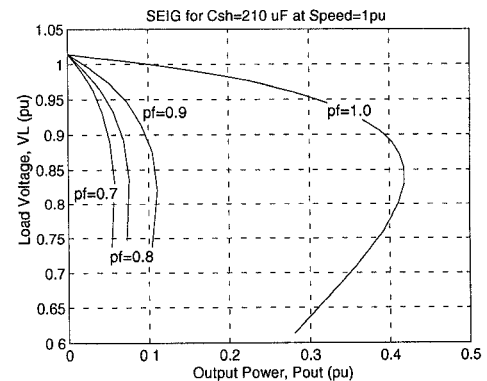

Fig. 4. Effect of power factor.

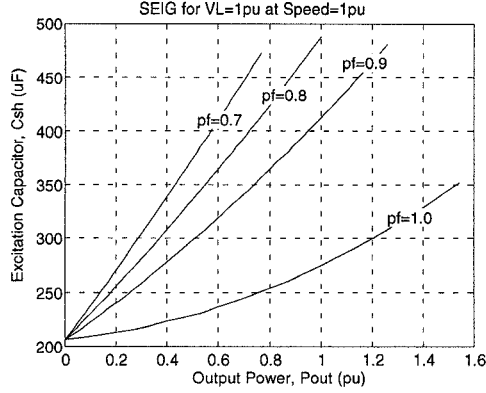

Fig. 5. Required leading VAR for constant voltage SEIG.

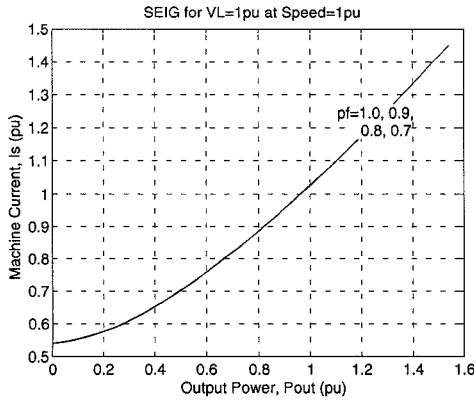

Fig. 6. Corresponding machine current for constant voltage SEIG.

## V. CONTROLLED SHUNT CAPACITOR SEIG MODEL

The Quasi-Rotating Reference Frame (QRF) [8] analytical approach is used to predict the transient behavior and the steady state performance of the controlled shunt capacitor SEIG. The QRF takes into account the sequential short-circuiting of the phase capacitors with its discrete jumps at every zero crossing. This approach reduces the complexity of finding the steady state solution to only three states.

Both q-axis and d-axis controlled capacitor voltages are non-zero, or only the q-axis controlled capacitor voltage is zero, or both q-axis and d-axis controlled capacitor voltages are zero.

The d,q model referred to the stationary reference frame of a controlled shunt capacitor SEIG that is supplying an inductive load consists of three parts.

### A. D,Q-Model of The Induction Machine

The SEIG depends solely on its non-linear characteristic of its magnetizing inductance to sustain excitation. Thus, the induction machine d,q-model must include the variable saturated magnetizing inductance instead of the linear magnetizing inductance. The d,q-model of the induction generator in flux linkage state variables,

$$p \lambda_{qs} = V_{qs} - (R_s / L_{ls}) \cdot (\lambda_{qs} - \lambda_{mqsat}) \quad (1)$$

$$p \lambda_{ds} = V_{ds} - (R_s / L_{ls}) \cdot (\lambda_{ds} - \lambda_{mdsat}) \quad (2)$$

$$p \lambda_{qr} = \omega_r \lambda_{ds} - (R_r / L_{lr}) \cdot (\lambda_{qr} - \lambda_{mqsat}) \quad (3)$$

$$p \lambda_{dr} = -\omega_r \lambda_{qs} - (R_r / L_{lr}) \cdot (\lambda_{dr} - \lambda_{mdsat}) \quad (4)$$

The calculation of saturated magnetizing flux linkages along the q-axis  $\lambda_{mqsat}$  and the d-axis  $\lambda_{mdsat}$  are performed using the model presented in [9].

### B. D,Q-Model of The Load Side

The d,q-model of the load side that consists of the excitation capacitors  $C_{sh}$  in parallel with an inductive load,

$$p Q_{qsh} = -I_{qs} - I_{qL} \quad (5)$$

$$p Q_{dsh} = -I_{ds} - I_{dL} \quad (6)$$

$$p I_{qL} = (V_{qs} - R_L I_{qL}) / L \quad (7)$$

$$p I_{dL} = (V_{ds} - R_L I_{dL}) / L \quad (8)$$

$Q_{sh}$  represents the charge across the excitation capacitor.

### C. D,Q-Model of The Prime Mover

The mechanical equation that describes the prime mover, which is a shunt DC motor is

$$d\omega_r / dt = (P/2J) \cdot (T_L + T_e) \quad (9)$$

where

$$T_e = (3/2) \cdot (P/2) \cdot (\lambda_{ds} I_{qs} - \lambda_{qs} I_{ds}) \quad (10)$$

$$T_L = T_0 + k_t \cdot (2/P) \cdot \omega_r \quad (11)$$

$T_e$  is the induction generator electromechanical torque and  $T_L$  is the mechanical load torque that is represented by the linear torque/speed relationship.  $P$  is the induction generator number of poles,  $J$  is the total inertia of the induction generator and the prime mover,  $T_0$  is the stall torque and  $k_t$  is slope. Note that the sign notation of all the state equations are based on the passive-sign convention.

## VI. HARDWARE IMPLEMENTATION

A simplified block diagram of the experiment hardware setup of the controlled shunt capacitor SEIG is shown in Fig. 1. The variable dc power supply excites the armature winding of the shunt dc motor, while its field current is maintained constant.

The dc motor drives the three-phase induction generator at its synchronous speed. Through the circuit breakers the induction generator is connected to a three-phase delta-connected capacitor bank. An anti-parallel switches ( $S_1$ - $S_6$ ) is connected across each capacitor. Each switch can be GTO or a combination of an IGBT in series with a diode for blocking the reverse voltage. The switches used in the experiment are the IGBT with the series diode as illustrated in Fig. 1. Finally

a three-phase load is connected across the induction generator terminals through a magnetic contactor.

The control part starts with sensing the line to line terminal voltages and the machine stator currents. These sensed voltage and current signals are fed to the control board to generate the adequate signals to the gate drive by the comparison of the output of the PI controller and the generated saw-tooth signal. Then the gate drive sends the required G1 to G6 pulses to turn on and off the related IGBT switch.

## VII. SIMULATION AND EXPERIMENTAL RESULTS

The simulation has been carried out using the digital computer simulation package Simulink.

Fig. 7, demonstrates the load line-line voltage and current transient response of the controlled shunt capacitor SEIG when a resistive load of 35.2 ohms (25% of the rated load) connected to its terminals at the start of interval II. Fig. 7, shows the load voltage climbs to the rated value in a smooth transient when the control loop is closed in interval III. The simulation waveforms are very close to those obtained from the experiment.

Fig. 8, shows the experimental transient response of the controlled shunt capacitor SEIG under closed-loop with a step change resistive load. During interval II a resistive load of 35.2 ohms is connected to the generator terminals. At the start of interval III the total resistive load is increased to 17.8 ohms (50% of the rated load). The load is disconnected from the generator terminals at the beginning of interval IV.

Fig. 9, compares the steady state voltage and current waveforms of the variable capacitor bank of the controlled shunt capacitor SEIG supplying a resistive load of 35.2 ohms between the experimental and simulation results. Fig. 9, displays, (a) the load line-line voltage  $V_L$  that is equal to the voltage  $V_c$  across the excitation capacitor, (b) the phase current  $I_c$  through the capacitor and (c) the total switch current  $I_{sw}$  through both anti-paralleled IGBT switches. The capacitor current  $I_c$  goes to zero when the IGBT switch turns on at zero voltage and diverges to the corresponding switch without a current surge.

## VIII. CONCLUSION

A new SEIG voltage regulation scheme that is the controlled shunt capacitor SEIG has been proposed and implemented. It is proven that proposed scheme can regulate the output voltage from no load to full load range with high performance. The obtained experimental results are in agreement with the simulation results. The operation under zero-voltage switching has been proven to have a negligible switching losses. This leads to smaller device power ratings, small heat sink and the no need for snubber circuits.

Therefore, the proposed controlled shunt capacitor SEIG is expected to be used as a high performance, reliable and cost effective self-excited induction generator.

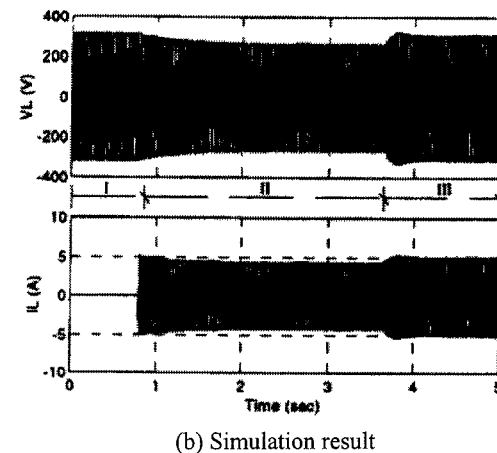
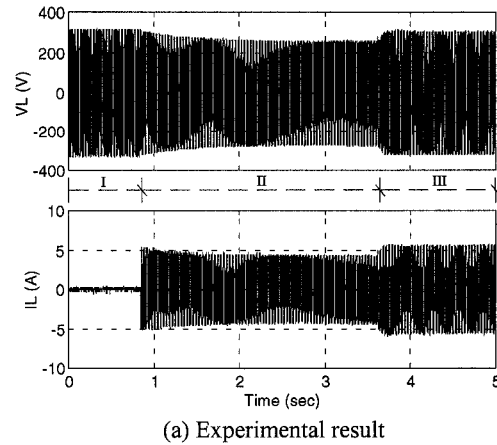

Fig. 7. Load line-line voltage and current for the open/closed-loop control.

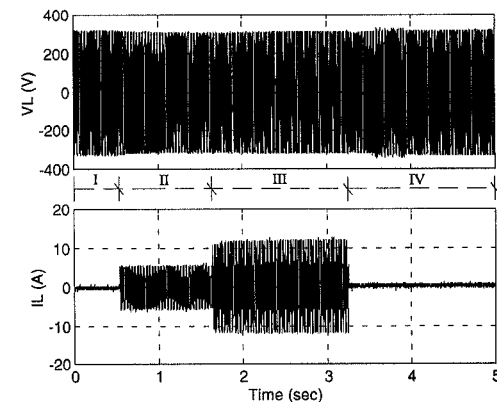

Fig. 8. Load line-line voltage and current for the closed-loop control.

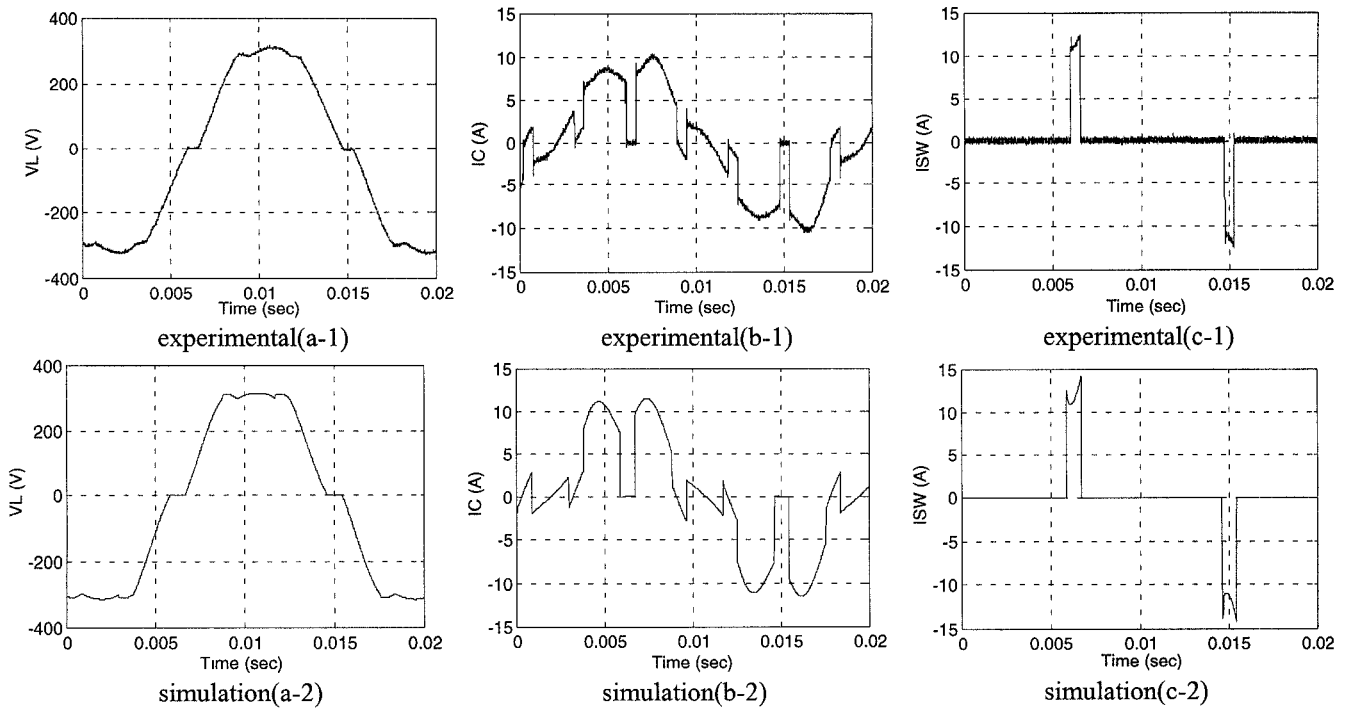

Fig. 9. The experimental and simulation results of the steady state voltage and current waveforms of the variable capacitor bank for a resistive load of 25% of the full load.

#### REFERENCES

- [1] Bassett and F.M. Potter, "Capacitive Excitation for Induction Generators", *Electrical Engineering*, Vol. 54, May 1935, pp. 540-545.
- [2] L. Shridhar, Bhim Singh, C.S. Jha, B.P. Singh and S.S. Murthy, "Selection of Capacitors for the Self-Regulated Short Shunt SEIG Excited Induction Generator", *IEEE Trans. on Energy Conversion*, Vol. 10, No. 1, Mar 1995, pp. 10-17.
- [3] E. Bim, J. Szajner and Y. Burian, "Voltage Compensation of an Induction Generator with Long-Shunt Connection", *IEEE Trans. on Energy Conversion*, Vol. 4, No. 3, Sep. 1989, pp. 526-530.
- [4] J.M. Elder, J.T. Boys, and J.L. Woodward, "Self-Excited Induction Machine as a Small Low-Cost Generator", *IEE Proc.*, Vol. 131, Pt. C, No. 2, Mar 1984, pp. 33-41.
- [5] .B. Brennen and A. Abbondanti, "Static Exciters for Induction Generators", *IEEE Trans. on Industrial Applications*, Vol. IA-13, No. 5, Sep/Oct 1977, pp. 422-428.
- [6] E. Muljadi, Y. Zhao, T.H. Liu and T.A. Lipo, "Adjustable ac Capacitor for a Single-Phase Induction Motor", *IEEE Trans. on Industrial Applications*, Vol. 29, No. 3, Sep/Oct 1993, pp. 479-485.
- [7] S.S. Murthy, O.P. Malik and A.K. Tandon, "Analysis of Self-Excited Induction Generators", *IEE Proc.*, Vol. 129, Pt. C, No. 6, Nov 1982, pp. 260-265.
- [8] N.H. Kutkut, H.M. Cherradi and T.A. Lipo, "Analysis of Voltage Controlled Induction Motors Using Quasi-Rotating Reference Frame", *Mathematics and Computer in Simulation* 38, 1995, pp. 271-281.

- [9] M. Osama, K. Sakkoury and T.A. Lipo, "Transient Behavior Comparison of Saturated induction Machine Models", *IMACS-TCI-93 Computational Aspects of Electromechanical Energy Converters and Drives*, Jul 1993, pp.577-580.

#### APPENDIX A

7.5 HP polyphase induction machine, 230 V / 19A 4 pole, and 60 Hz.  $R_s = 0.195$  ohms,  $R_r = 0.177$  ohms,  $L_{ls} = 1.313$  mH,  $L_{lr} = 1.969$  mH and  $L_{mu} = 38.781$  mH. Base values are  $V_B = 133V$ ,  $I_B = 19A$ ,  $Z_B = V_B/I_B$  and  $P_B = V_B * I_B$ . With machine rated power  $P_{BR} = 5.595KW$ , the  $P_{pu} = (P_{out}/P_B) * (3 * P_B/P_{BR})$ .

The table below shows the no-load test data points for the 7.5 HP induction machine.

$V_L^{ph}$ [Volts]	$I_m$ [Amps]
36.00	2.46
93.01	6.24
104.56	7.14
115.82	8.27
122.05	8.88
127.54	9.51
133.83	10.60
138.85	11.33
144.05	12.48
150.40	14.08
156.75	16.37
166.62	20.00
184.29	28.00